



HighOne-Pro User Manual_V1.0

www.zerouav.com

Contents

1 Product Introduction.....	1
2 Product List (subject to the real parts)	2
3 Before flight (Important)	4
3.1 Installations.....	4
3.1.1 Landing gear installations	5
3.1.2 GPS installations	6
3.1.3 Quad arm installations.....	7
3.1.4 Propeller installations	8
3.1.5 Gimbal installations	9
3.1.6 Camera installations	10
3.1.7 Camera center of gravity adjustment.....	11
3.1.8 Wiring diagram	12
3.1.9 NOTICE	13
3.2 GCS installation (ground control station)	15
3.2.1 Installation of Mobile GCS	15

3.2.2 Installation of PC GCS.....	15
3.3 WIFI Configuration.....	16
3.3.1 WIFI Communication Mode	16
3.3.2 WIFI Communication link.....	16
3.4 Setting up the Remote control transmitter (taking FUTABA remote controller for example)	17
3.4.1 Setting up a single remote control	19
3.4.2 Setting up a dual remote control.....	21
3.5 Energizing.....	25
3.5.1 Inspecting the aircraft prior to energizing.....	25
3.5.2 Power-on operation steps.....	26
3.6 Test Parachute Opening/Closing (Parachute is optional accessory)	30
3.6.1 Android GCS test.....	31
3.6.2 PC GCS test.....	32
3.7 Calibrating the Magnetic Compass	32
3.7.1 Using the Android GCS	32
3.7.2 Compass Calibration Using a PC Ground Station	35

3.8 How to unlock motors before flight.....	39
4 Flight operation (Important).....	42
4.1 Careful attention during flight.....	42
4.2 LED Status Indications	44
4.3 Flight mode	46
4.4 Flight using a single remote control	47
4.4.1 FPV mode	47
4.4.2 Carefree mode (only for GPS Hover Status)	51
4.4.3 Aerial rocker function.....	53
4.5 Flight using dual remote controls.....	55
4.5.1 FPV mode	55
4.5.2 Carefree mode.....	58
4.5.3 Aerial rocker	60
4.5.4 Panorama photography.....	62
4.6 Landing.....	63
5 Introduction to Functions.....	64

6 System Introduction	69
6.1 Parameters	69
6.2 Composition.....	71
6.2.1 Flight control.....	72
6.2.2 Gimbal	74
6.2.3 Communication link	76
6.2.4 Parachute	76
6.2.5 Landing Gear.....	77
Appendix 1 Calibrating your remote control. (RC transmitter).....	79
Appendix 2 Reset gimbal gyro to zero	82
Appendix 3 Supported by Zero UAV technology.....	84
Appendix 4 Manual revisions	84
Appendix 5 CE	85

Warnings and Disclaimer



DANGER

Thank you for purchasing this ZERO UAV product. The product is an advanced and specifically dedicated control item. Any misuse may result in damage to property, injury or even death. The user must conform to the law and use the equipment responsibly. This product is not suitable for people under the age of 18. Please read this disclaimer and manual carefully before using the product as well as visiting the HIGHONE web page at <http://www.zerouav.com> to refer to relevant updates or information.



WARNING

- ❖ Please keep the product out of reach of children.
- ❖ Make sure the aircraft is kept away from people and dangers such as buildings roads and property. We suggest you fly

your aircraft at specially designated areas.

- ❖ Please do NOT fly this product when affected by drunkenness, tiredness, drugs, dizziness fatigue, nausea or any other condition that might impair your ability to control the aircraft.
- ❖ Please strictly follow the user manual when operating the device.
- ❖ Please make sure all components of the device are connected and work well, otherwise your unit may be damaged, destroyed or even buried!
- ❖ Please power off and remove propellers before making any adjustments to the unit such as calibrating, upgrading firmware or changing parameters. There is an ever present danger of the propellers starting unexpectedly and causing injury.
- ❖ Please do NOT fly in unfavorable conditions.
- ❖ Please do NOT open or modify the autopilot, there are no user serviceable parts inside.



1. This product is completely under the control of the user. Users are responsible for all actions carried out whilst using this product, and the manufacturer shall not bear any responsibility for any consequence or liability caused by any direct or indirect use of this product.
2. Whilst using this product , the user must bear legal responsibility for any action that violates public order public security or public safety.
3. We will not provide any technical support nor safety commitment for any of the following conditions:
 - a) Organizations or individuals obtaining this product through informal agents. abnormal channels or unrecognized suppliers ;
 - b) Products modified, commissioned or having parts replaced without authorization
 - c) Products without warranty card, serial number or flight data;

Personal injury and property loss caused by factors such as personal operation error, natural disaster or Force Majeure.

TERMS AND ABBREVIATIONS

NAME	DESCRIPTION	NAME	DESCRIPTION
GEMINI	GEMINI, dual-redundancy autopilot (M+S)	GEMINI M	Master controller
GEMINI S	Slave controller	IMU	Inertial measurement unit
COMPASS	Magnetic compass	GCS	Ground Control Station software
Dual Remote control Operation	Aircraft remote control (RC Transmitter) + gimbal remote control (RC Transmitter)	Single Remote control operation	Aircraft and gimbal controlled by a single remote control at the same time.
CH	Channel; for example CH5 is channel 5.	F/S	Fail Safe; Control failure

	<p>The channels of the remote control can fulfill different functions in varying scenarios.</p>		<p>protection</p>
<p>OSD</p>	<p>On Screen Display (The display that overlays image data on the video down-link)</p> <p>Supported products can enhance the user experience by overlaying relevant flight data on the video downlink.</p>	<p>FPV</p>	<p>First Person View, The pilot is able to fly the aircraft from the camera view.</p>
<p>carefree</p>	<p>In this mode, the navigation direction of aircraft is locked to the heading of the gimbal automatically avoiding obstruction of the landing gear.</p>		

1 Product Introduction

The HighOne-Pro is an all in one, fold-able 4-axis aerial photography aircraft system researched and developed by a professional photographer ZERO TECH. It integrates the Gemini professional flight control autopilot and carries the Z1400 (GH3) 3-axis brush-less gimbal. The HighOne-Pro is small and convenient, it is easy to carry and it can fly immediately after delivery. It is particularly suited to specialized conditions such as flying close to obstructions, in narrow areas or in enclosed spaces such as stadiums or indoors. It can be widely used in the television industry, for commercial promotions and all kinds of professional aerial photography.

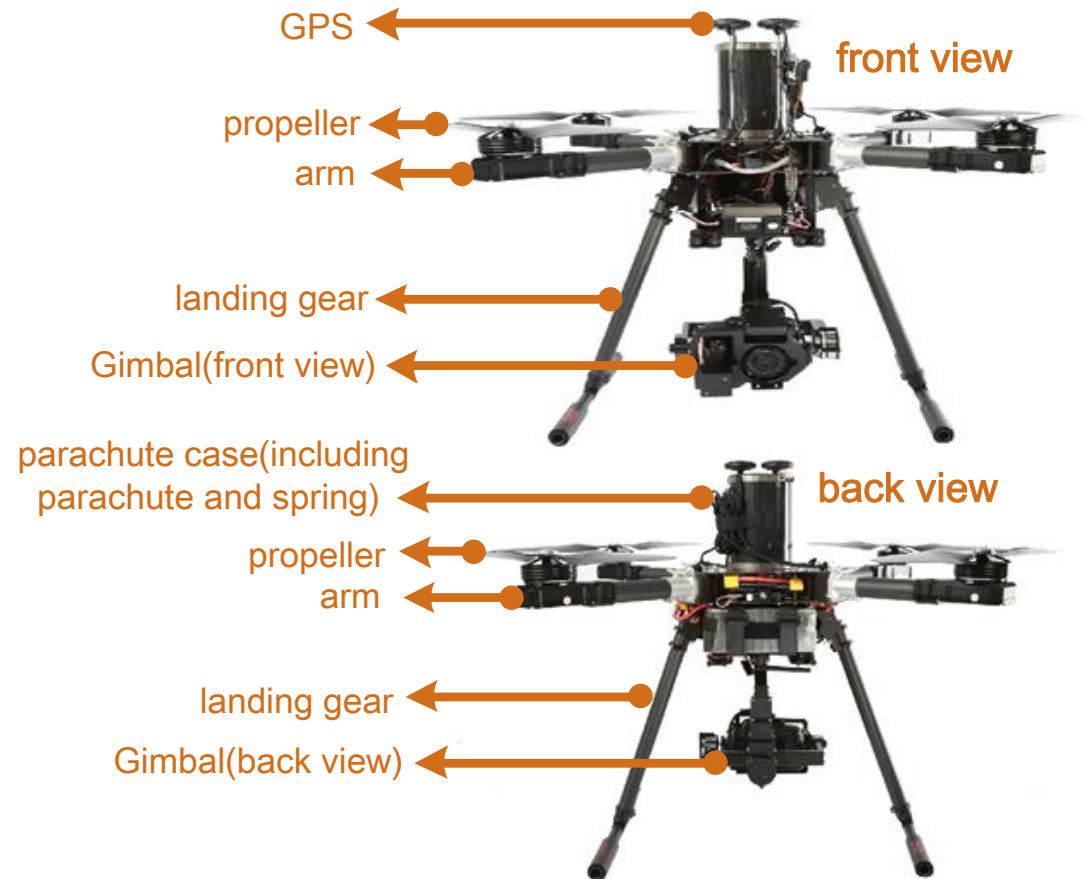

Figure 1 Schematic Diagram of copter

2 Product List (subject to the real parts)

- Standard

ITEMS	DESCRIPTION	ITEMS	DESCRIPTION
Frame (including motors and electronic speed controls (ESCs))	Arm(M1-M4),landing gear,copter body	Flight control	GEMINI M (Master controller), GEMINI S (Slave controller)
Gimbal	Z1400	GPS module	There is GPS module for Gemini M and Gemini S individually
Wi-fi module (WLAN)	Wifi is for Gemini M and Gemini S is individually(Wifi antenna is in the accessory bag)	Power Supply Module	Main Power Supply Unit, Gimbal Power Supply Unit
S-BUS converter module	Normal receiver connect to the FC or gimbal by this module	OSD	ZerOSD mainframe and its wiring
Propeller	18×5.5inch Carbon fiber	landing gear retracts	Left and right retractable landing gear

- Optional

ITEMS	DESCRIPTION	ITEMS	DESCRIPTION
Security parachute	Parachute can open to protect camera in emergency	Lipo Battery	Power supply to FC,gibal,etc. (6S , 16000mAh , 15C)
Data link	Lengthen the control distance.		

- Accessories

ITEMS	DESCRIPTION	ITEMS	DESCRIPTION
Flashlight hot shoe	To fix the camera	3P merging line FUTABA dual pin L=150	10 pcs with label of S-BUS,2 pcs with label of S-BUS
WiFi antenna	It need to connected with wifi	S - BUS conversion module	Spare parts
U disk	《HighOne-Pro manual》 included	HDMI lead	GH3 / GH4 HDMI lead,

			Connect gimbal and camera video output interface
USB to serial converter	Used to firmware upgrade,parameter adjustment and wifi setting	Product certificate + warranty card	Maintenance record
Magic belt with buckle	2 belts, 25×400MM,be used to fix battery	Propeller gasket	Be used to fix propeller
Disclaimer card	One English version and one Chinese version, Be used to label danger,warning and disclaimer clauses	WiFi information card	Be used to label WIFI model,SSID and password
		Screws	—

3 Before flight (Important)

3.1 Installations

All of the cables of HighOne-Pro is connected well before sending out of factory, **don't change the connections of cables, just do as the following and then HighOne-Pro can be adjusted to fly:**

3.1.1 Landing gear installations

Step1, fix the vertical pipe(long pipe) and horizontal pipe(short pipe) by a M3*10 screw

Step2, loosen four M3*25 screws, install two pipe clamp to vertical pipe, **insert the spring to vertical pipe**. Tighten four M3*25 screws, **horizontal pipe(short pipe) should face to the head of copter**.

Step3, tighten two M4*30 screws, fix the landing gear.

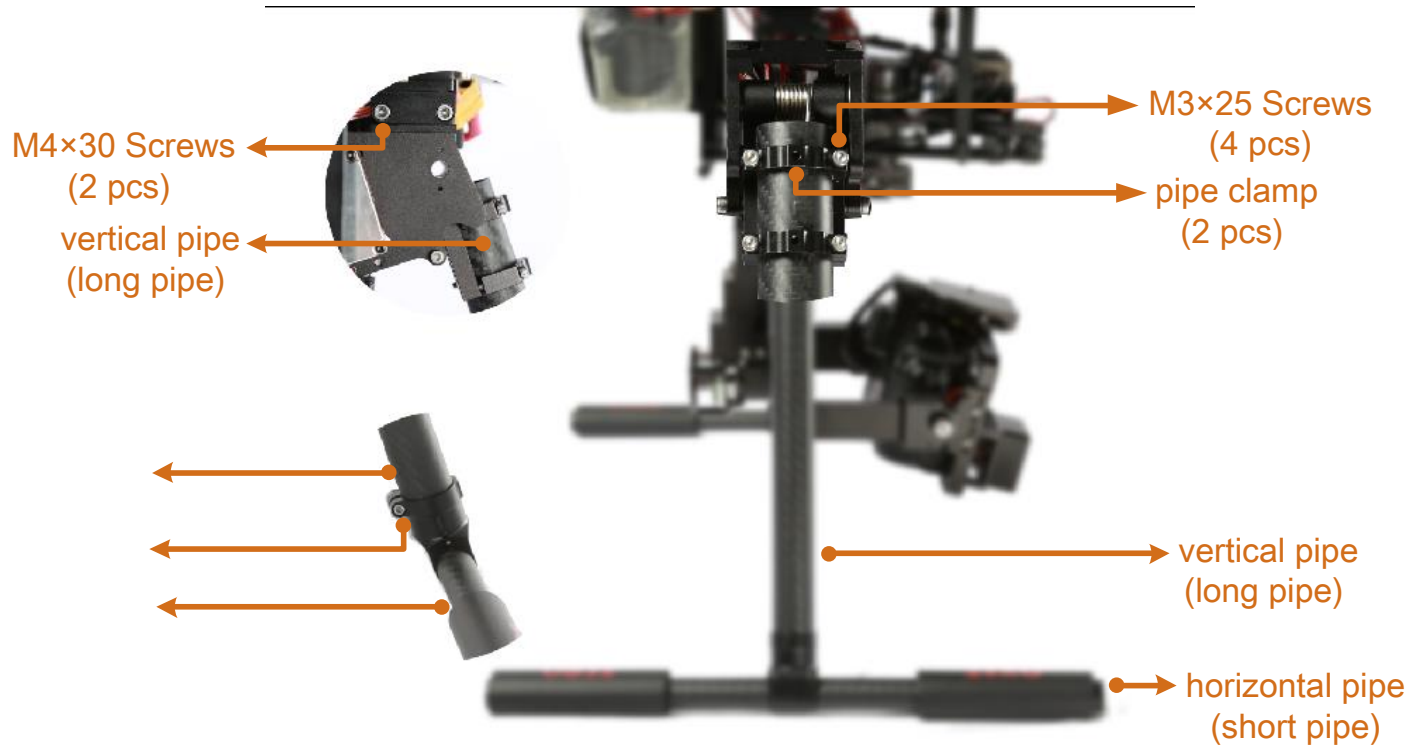

Figure 2 Landing gear installations

3.1.2 GPS installations

Step 1, Hold up 2 set of GPS brackets, ensure the arrow on the GPS face to the head of aircraft(between M1 and M2),. Note:

GPS bracket should be vertical to horizontal direction, GPS arrow should be parallel to copter head direction.

Step 2, Tighten the nuts on the base

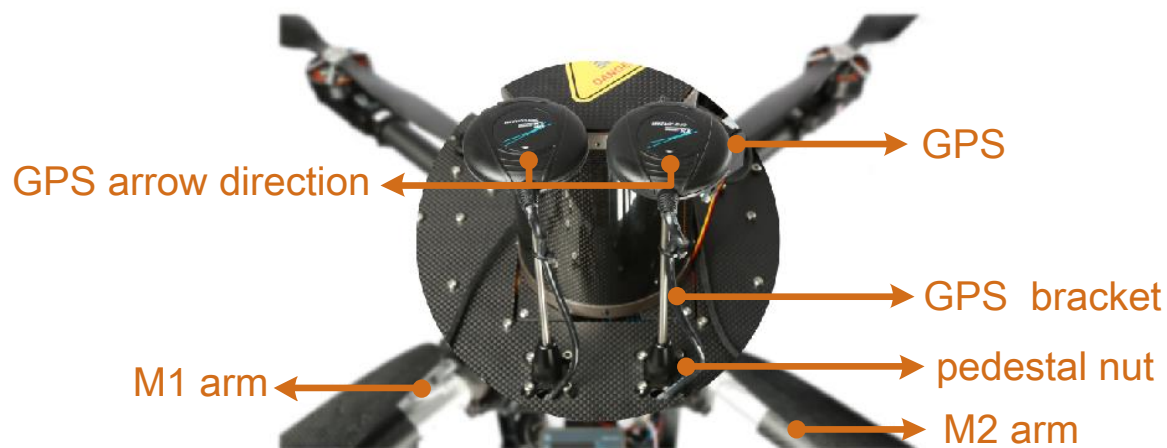

Figure 3 GPS installations

3.1.3 Quad arm installations

Step 1, Aircraft arm installation position is selected by the label of M1 to M4.

Step 2, Three pin plug should be plugged into the three hole plug of articulation base, then connect the aircraft arm and aircraft body by screwing M4×42 bolts.

Step 3, Fasten the clamp, and one arm is finished. The same method to the other three.

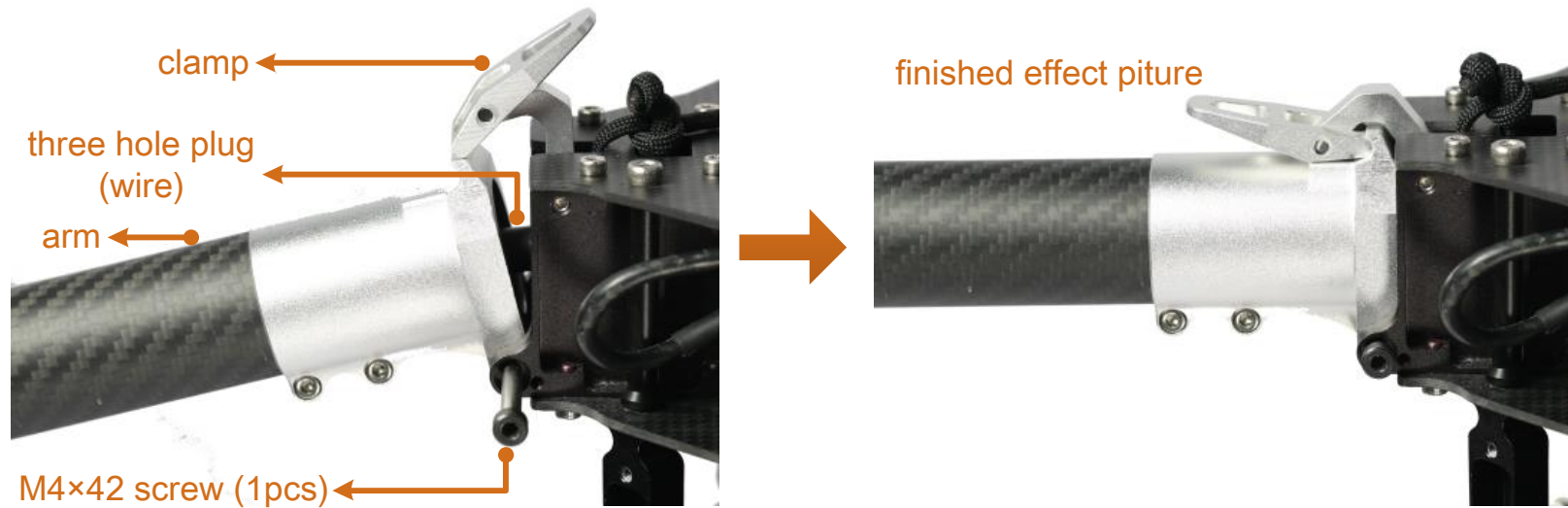

Figure 4 Quad arm installations

3.1.4 Propeller installations

Propeller is in the down position, gasket is in the up position, tighten 2 set of M3×14 bolts, it's finished.

Anticlockwise propellers for M1 and M3, clockwise propellers for M2 and M4. Propellers rotation direction

see Figure 5.

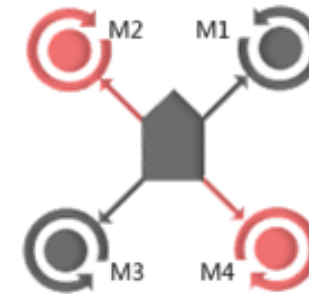

Figure 5 Propellers rotation directions

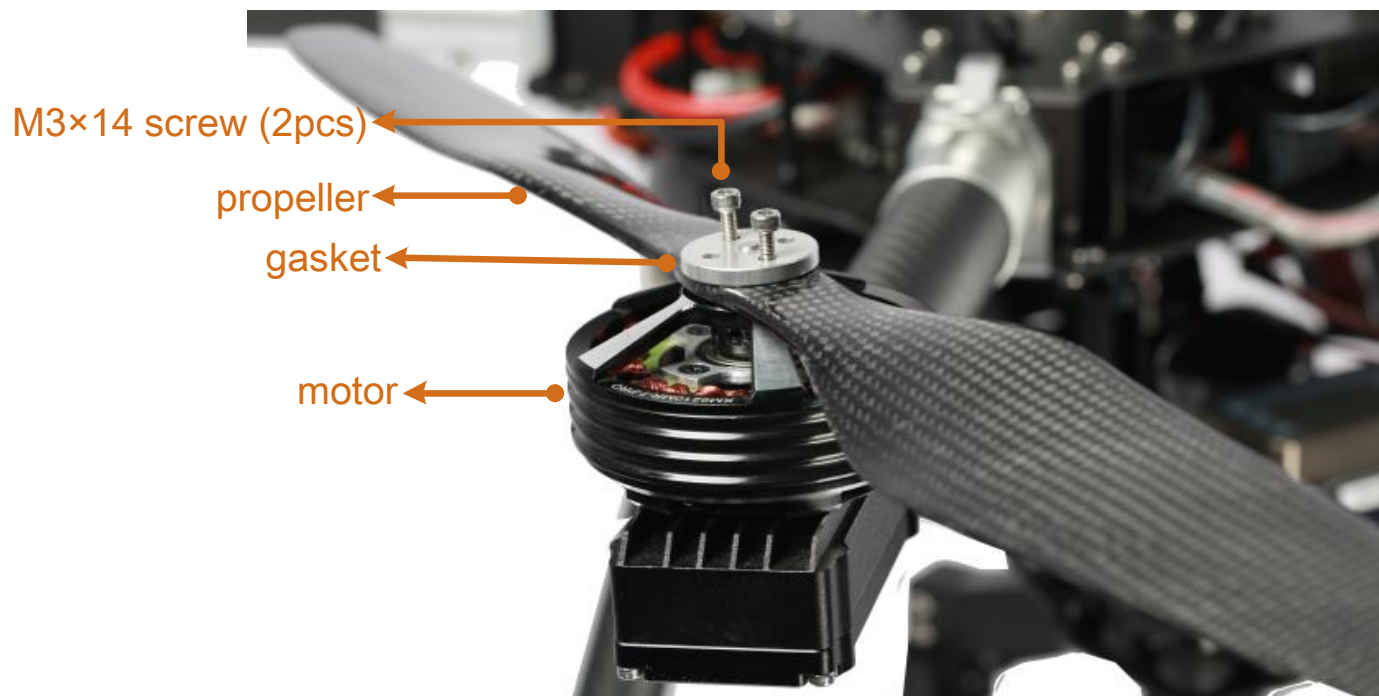

Figure 6 Propeller installations

3.1.5 Gimbal installations

Gimbal installation: Carbon plate and connector between copter and gimbal is fixed by 8 set of M8×8 round hexagonal socket screws.

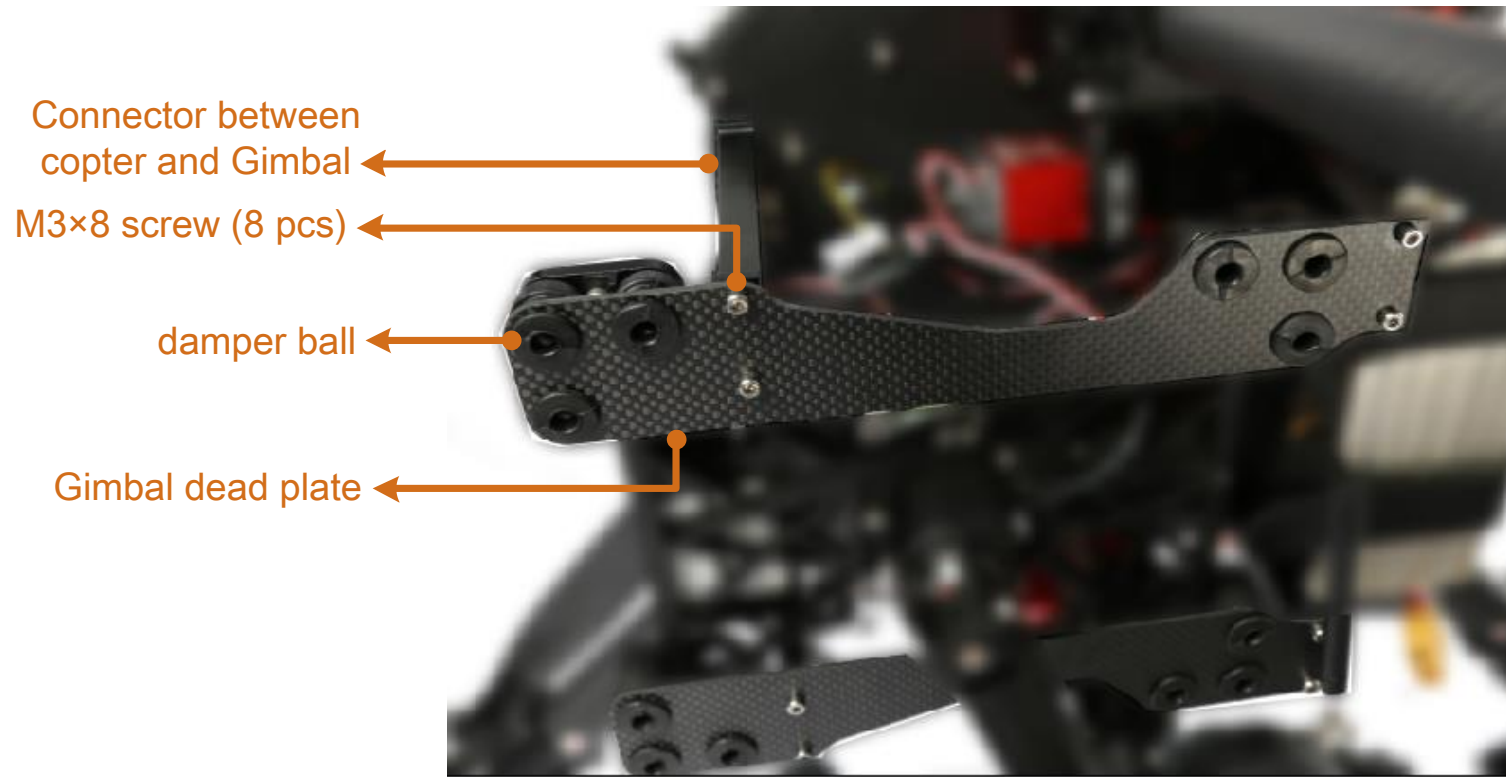

Figure 7 Gimbal installations

3.1.6 Camera installations

Step1, install the hot shoe to the slot of camera.



Figure 8 push the hot shoe into the slot

Step2, fix the camera to the upper pendant by screws in figure

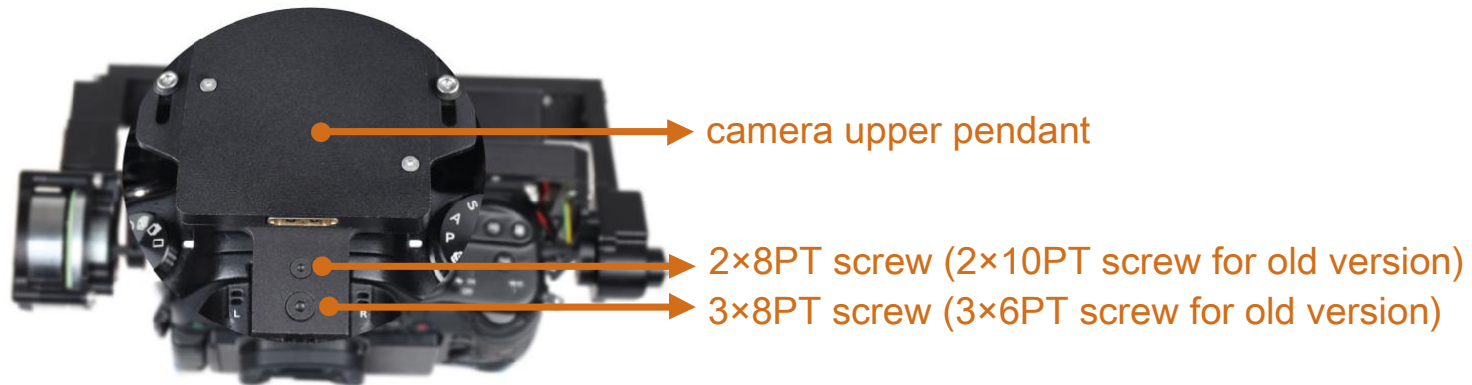

Figure 9 fixing with upper pendant

Step3, fix the camera to the lower pendant by screws in figure

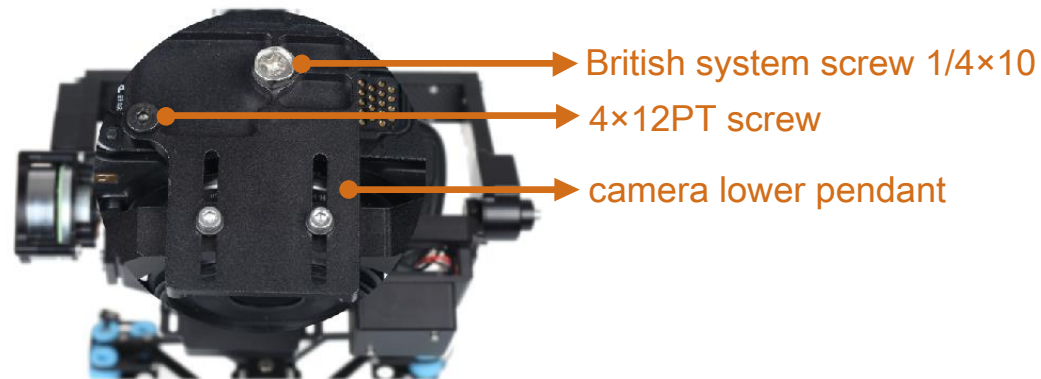

Figure 10 fixing with camera lower pendant

Step4, use standard HDMI video switch line to Gimbal video port and camera video output port

Note:

- Take out the peripherals of the camera(such as filter and hood),camera center of gravity need to be adjusted again by customer if other peripherals need to be added.
- Check the installation of battery ,memory card and focus; shutter speed need to be set to 1/120s,otherwise may lead to jelly or jitter.

3.1.7 Camera center of gravity adjustment

HighOne-Pro has got center of gravity with GH3 camera and Lumix G 14mm f/2.5 lens when leaving factory.It should be readjusted if changing camera or lens.Center of gravity adjustment video:

http://v.youku.com/v_show/id_XODkwMjc5ODky.html

3.1.8 Wiring diagram

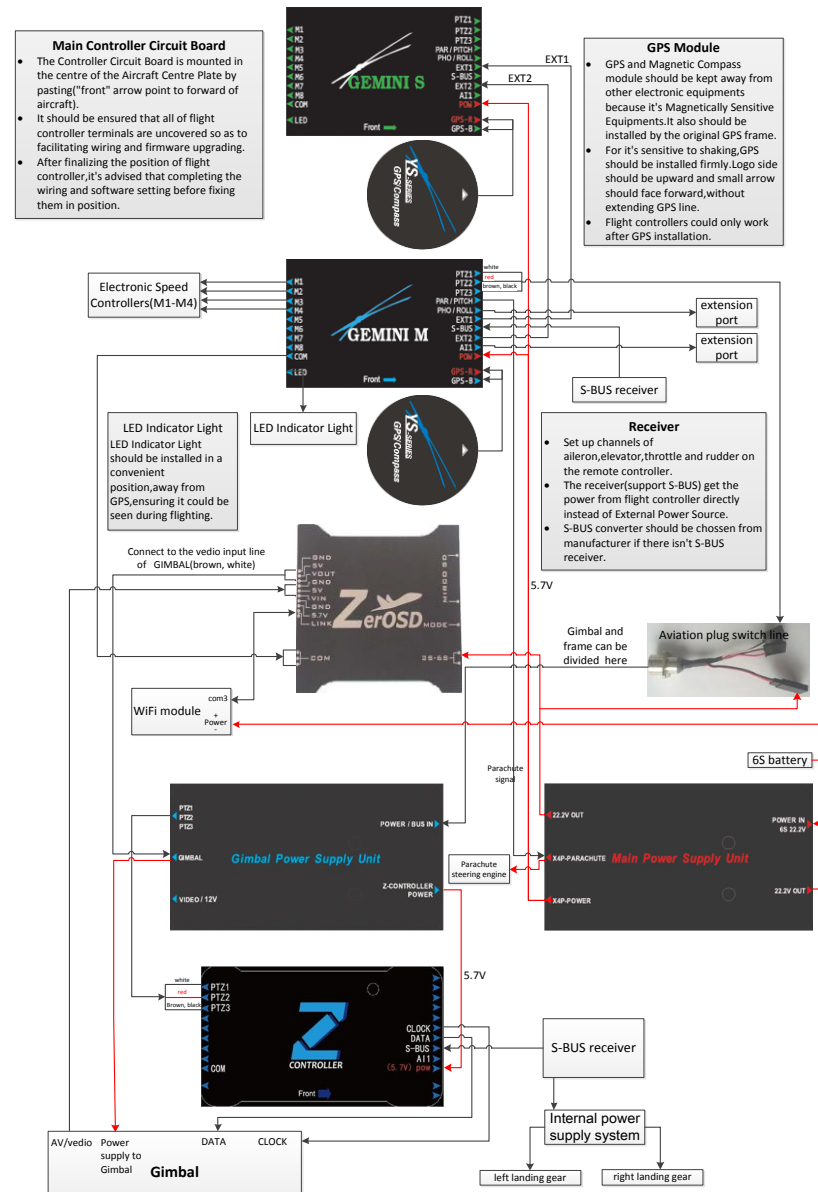

Figure 11 Wiring diagram

NOTE: Signal wire of retractable landing gear could be connected with empty channel of gimbal receiver, or it also could be connected with empty channel of copter receiver.

3.1.9 NOTICE

1. **The Gemini flight controller and Gimbal controller both use the 5.7v power supply.** If the main voltage supply from the 6s battery is used the equipment will be fried immediately.
2. Please be sure to use a 6S LIPO battery to supply power to the gimbal. If a 4S or 5S battery is used, the gimbal will have insufficient strength, will shake and behave abnormally.
3. The XT90 power supply connector may easily become dirty and have a poor contact making the wires become too hot after a flight. This may be rectified by:
 - Regularly clean with ethyl alcohol to eliminate carbon traces after sparking.
 - Replace the anti-ignition connectors using the genuine AMASS variety.
4. There is COM port for each of the main controller and slave controller of HighOne-Pro, **the extension cord of main controller is M-COM, and the slave controller is S-COM.** When upgrading the flight control firmware, insert the USB line into its corresponding COM interface to start the upgrade operation (when upgrading the main controller, the OSD data wire should be disconnected).

5. When installing the battery, please pay attention to the following:

a battery need to be installed in the tail of the copter, output line direction should be vertical to copter head.

b Battery should be tighten by the fixing strap, otherwise it have the risk of battery loosen.

6. After connecting all wires, connect the battery, supplying power to the flight controller and power to the system at the same time so as to avoid restarting the flight control and generating an error.

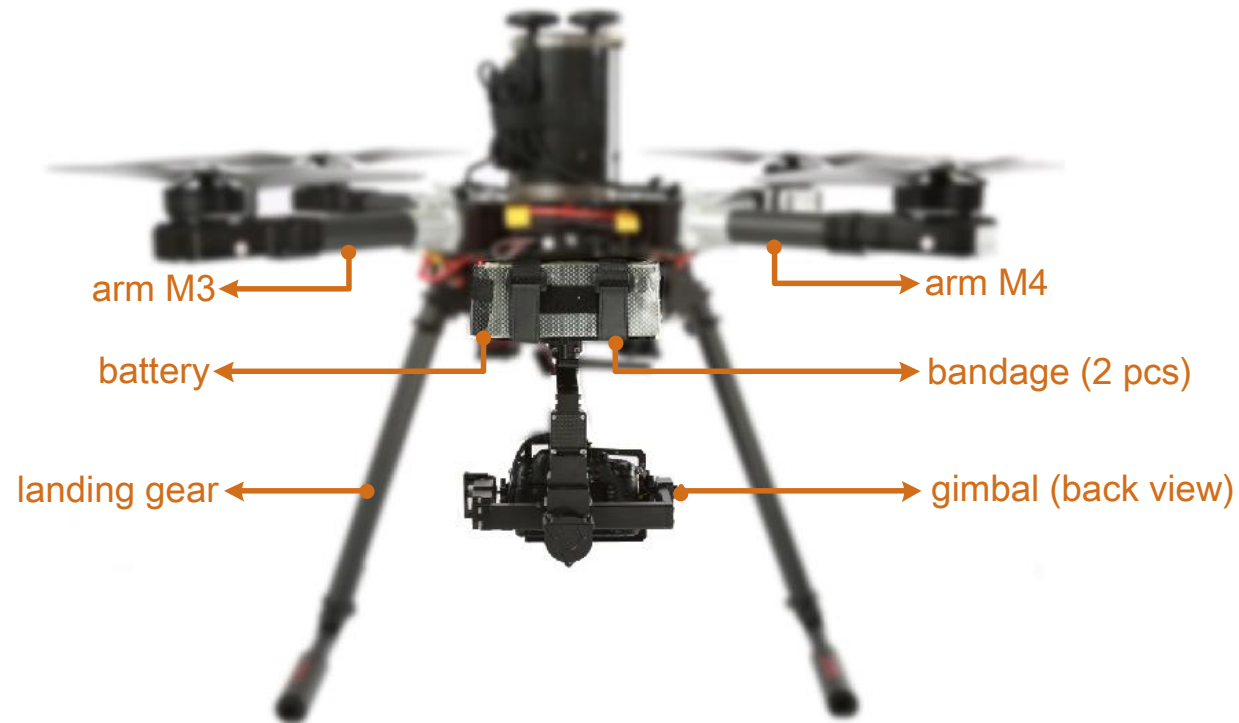

Figure 12 Battery installation

3.2 GCS installation (ground control station)

3.2.1 Installation of Mobile GCS

Android mobile GCS should be installed as follows:

1. Download YS-GCS Android mobile software from the download section in the support zone of the official website (www.zerouav.com).
2. Automatically install the software by clicking on the APK file in the file manager. The ground station App will appear on the mobile device desktop after installation as shown in Figure13. The GCS must be installed in the memory of the mobile.



Figure13 GCS
(ground control station)

3.2.2 Installation of PC GCS

Download the YS-GCS PC software from the download section in the support zone of the official website (www.zerouav.com).

After decompressing, double-click the ZERO-GCS Rotor Ground Station.exe file to install the program.

3.3 WIFI Configuration

3.3.1 WIFI Communication Mode

The Gemini Wi-Fi system can support two communication modes: point-to-point (P2P) and router. **The delivery default setting is point-to-point mode with an SSID of ZERO-TECH and no password.**

After the link is completed all flight data will be recorded to the ground station. The file with the extension of “.hjext2” can be found in the directory “YShj” in the root directory of a mobile device or in the file folder “Hj” in the PC ground station software package. This file can be replayed and analyzed in the PC GCS application.

3.3.2 WIFI Communication link

A Wi-Fi configuration tutorial can be found at: http://v.youku.com/v_show/id_XNTE2OTY4MjQ4.html.

3.4 Setting up the Remote control transmitter (taking FUTABA remote controller for example)

Your RC transmitter (TX) must use “fixed-wing mode”, do not set up any mixes. If using a Futaba TX, none of the channels should be reversed (**except the channel of retractable landing gear**). JR, Tiandifei and possibly other remote controls should have all channels reversed. Video refer to: <http://www.tudou.com/programs/view/e1ai526Mbt4/>

When operating single remote controller or double remote controller, the remote controller which control the retractable landing gear need to be set as following:

1. **wire connection**, control line on the retractable landing gear(label with **landing gear**) need to be connected to correspond channel on the receiver.
2. Side lay HighOne-Pro or support it by frame, hand the landing gear in the air.
3. Open the remote controller, **do the reverse setting first**: LNK→REVERSE→ set corresponding channel to REV, after reverse setting, landing gear get down when at position 1; it's flying status when in position 2.
4. Then **set the stroke**: LNK→END POINT , set the two middle line of landing gear channel to 120(CH9 as an example in the following picture)



Figure 14 stroke setting

Note: the following project should be checked after setting well:

- Turn the channel of landing gear to position 1, setting is ok if landing gear get down and support the copter well.
- Turn the channel of landing gear to position 2, setting is ok if landing gear uplift and be parallel to the ground.

3.4.1 Setting up a single remote control

NOTE:

- Manual mode is the most top priority. Whatever any mode, copter will switch to manual mode if CH5 switch to top position, copter will be controlled by operator.
- User need to use remote controller and receiver more than 9 channel if need to use CH1 to CH8 and retractable landing gear. Insert control wire (label with landing gear) of landing gear to landing gear channel in the receiver of remote controller.

- Single remote controller channel definition.

Channel	Definition	Description
CH1	Aileron channel	Copter horizontal movement control
CH2	Elevator channel	Copter forward and backward control
CH3	Throttle channel	Copter rise and fall control(rise in big throttle, fall in small throttle)
CH4	Rudder channel	Copter circle around control

CH5	Working mode choosing channel	Refer to the following table
CH6		
CH7	Gimbal pitch control, single or double remote control switch channel	Gimbal pitch control, single or double remote controller switch
CH8	Shooting and record control channel	Control the camera shooting/record(taking a picture, begin/stop recording video)

NOTE: see remote controller channel method: power on remote controller→MOL→SERVO.

- Working mode setting.

CH5 Position	CH6 position	Work mode
CH5 position 1	any position	Manual
CH5 position 3	CH6 position 1	Auto hover
CH5 position 3	CH6 position 2	Auto navigation
CH5 position 3	CH6 position 3	Return to land

- Single remote controller setting by following step:
 1. Set both CH5 and CH6 to 3-position switches. CH5 and CH6 select the working mode of the flight control.
 2. Fail Safe (F/S) should be set up with the controls in the following positions: Set both CH5 and CH6 of the remote control to position 3. The throttle stick should be set to a position near the center (50%).
 3. Set CH7 to use a lever to control the gimbal Pitch. On a Futaba this would be the RS or LS switch lever(in the side of remote controller). **Switching CH7 of copter remote controller from up to down and back to up and repeats 3 times, then copter will be controlled by single remote controller. Gimbal will follow the real time copter direction, gimbal roll is horizontal, gimbal pitch is controlled by CH7.To switch to double remote control back from single remote control: repeating switching CH7 up and down 3 times.**
 4. Set CH8 to a 2-position switch to control the camera shutter. Taking a picture at each switch, or starting/stopping recording.
 5. Set a 2-position switch or knob switch on the remote controller to control the retractable landing gear.

3.4.2 Setting up a dual remote control

3.4.2.1 Copter remote controller settings

- Double remote controller-copter remote controller channel definition

Channel	Definition	description
CH1	Aileron	Get control of horizontal movement of copter
CH2	Elevator	Get control of forward or backward of copter
CH3	Throttle	Get control of rise or fall of the copter(rise in big throttle,fall in small throttle)
CH4	Rudder	Get control of circle around of copter
CH5	Work mode selection	Refer to the following table
CH6		

NOTE: the method to view the channel of remote controller: power on remote controller→MOL→SERVO.

- Work mode setting

CH5 status	CH6 status	Work mode
CH5 position 1	any position	Manual
CH5 position 3	CH6 position 1	Auto hover

CH5 position 3	CH6 position 2	Auto navigation
CH5 position 3	CH6 position 3	Return to land

- Copter remote controller setting steps

1. Set both CH5 and CH6 to 3-position switches. CH5 and CH6 select the working mode of the flight control.
2. Retractable landing gear control: If the signal input wire of retractable landing gear control module connect to empty channel, then the corresponding channel on the copter controller is set to two-position switch or knob switch, using to control the retracting of landing gear.
3. Fail Safe (F/S) should be set up with the controls in the following positions:

Set both CH5 and CH6 of the remote control to position 3. The throttle stick should be set to a position near the center (50%).

NOTE: Manual mode have the highest priority. Flight status will get back to manual mode whatever mode it is, copter will be controlled by the operator.

3.4.2.2 Gimbal remote controller setting

- Double remote controller-Gimbal remote controller channel definition

Channel	Definition	Description
CH1	Aileron channel	Gimbal roll control
CH2	Elevator channel	Gimbal pitch control
CH3	Throttle channel	Add force to the gimbal when pushing up, decrease force to the gimbal when pulling down
CH4	direction channel	Gimbal direction control
CH5	position 1	No direction follow
	position 2	Direction follow lock
	position 3	Direction follow with 5° lag
CH6	position 1	Low speed
	position 2	Mid range
	position 3	Fast

NOTE: method to view remote controller channel: power on remote controller→MOL→SERVO.

- Gimbal remote controller setting step

1. Set a 3-position switch to CH5,controlling gimbal work mode; set a 3-position to CH6,adjusting gimbal revolving speed.
2. Retractable landing gear control: If the signal wire of retractable control module is plugged in an empty channel of gimbal receiver, then correspond channel is set into 2-position switch or knob switch, for controlling the retractable landing gear.
3. CH8 is set to a 2-position switch, controlling the shooting and recording.

3.5 Energizing

3.5.1 Inspecting the aircraft prior to energizing

- ❖ Make sure of 6s battery, remote controller sufficient.
- ❖ Check propeller nuts are tight – if they are too loose a propeller may be thrown off.
- ❖ Check motor Installation is secure and none of the motors are loose.
- ❖ Check the landing gear is securely attached and all screws tightened.
- ❖ Check the centre of gravity after securing the battery.
- ❖ Check all connectors and cables are secure.

- ❖ Check the arrows on the flight control and the GPS are pointing to the front of the aircraft and are both secure.
- ❖ Check the centre of gravity of the gimbal. The camera should be stable and centered. When the gimbal is not powered the camera should maintain its position in any condition of pan, tilt or roll.
- ❖ Check that motor mixing control is correct.
- ❖ Check the angle status, number of GPS satellites locked and other relevant data in the ground station.

3.5.2 Power-on operation steps

The aircraft may be energized following these steps.

1. The remote control must be switched on first, switch to manual mode and pull the throttle back to zero. Now connect power to the motors and flight controller. The flight control system will now start up. **The default value is operation by dual remote control.**
2. Check that the flight control is normal; check that the type of aircraft and its reported angle are correct in the Android ground station app.
 - Android GCS: This can be checked in the “data” section of the app. All values should be active. (Not frozen!). The type of aircraft can be checked in the "parameter" section of the app.
 - PC GCS: select “file” then “open Wi-fi”. Pop out the flight data column. In “Gemini data” check that the flight control

is normal; in "other data" the angle status may be checked. Select "setting" then "parameter setting" to check that the type of aircraft is correct.

3. Confirm in the ground station data section that CH5 and CH6 of the aircraft transmitter are switching to the correct flight modes; and that the setting of fail-safe (F/S) is correct by switching off the transmitter and check that the flight status is displayed as "Return to land".

4. If you are using the HighOne-Pro for the first time you need to carry out the following operations:

- ❖ Conduct stick-calibration on all channels of the aircraft remote control transmitter. Please refer to Appendix 1. "Calibration of remote control" for detailed instructions.
- ❖ Switch on the parachute so that it is able to open automatically.

On the Android ground station: click the "default" button in the "parameter" section.

On a PC ground station: select "settings" then under "parameter settings", in the pop out window, click the "restore defaults" button.

5. In order to increase gimbal stability, manual detection of orientation should be carried out before starting. By hand gently rotate each axis of gimbal for 360° and then level the camera. The lens should stay pointing forward and note the correct upward and downward direction.

NOTE: Each time the aircraft is energized the gimbal must be initialized as described above.

6. Depending upon whether you are adopting the single or dual remote control method you need to carry out the following operations:



Figure 15 Gimbal initialized

❖ Single Remote control operation

- a) Switch CH7 on your aircraft remote control from Maximum to minimum. Now switch 3 times in rapid succession to enter single remote control operation. The gimbal will now be controlled by the aircraft remote controller. **Repeat this operation by switching 3 times again to exit single remote control operation and enter double remote control operation.**
- b) To check whether you have successfully entered single remote control operation or not: slightly raise the throttle stick, if all is in order, the gimbal will start stabilizing. It will tilt and roll to stay level and the CH7 switch will control gimbal tilt.
- c) When the throttle is reduced to zero the gimbal will cease stabilisation.

❖ Dual remote control operation

Push the throttle stick on the Gimbal remote control to its maximum. The gimbal will be at maximum stability. Use the gimbal remote control to regulate the roll, tilt and pan of the gimbal.

NOTE: : If the gimbal fails to maintain roll and tilt stability after initialization it is necessary to increase the throttle control until the camera maintains a level horizontal position and directional stability..

3.6 Test Parachute Opening/Closing (Parachute is optional accessory)

The PAR/PHO output channel on the Gemini flight controller is a PWM square wave signal, to control the operation of the parachute servo. The parachute opening servo must be powered separately from the flight controller. The mobile ground station can be used to test the operation of the parachute.

NOTE:

- Press the parachute capsule cover to prevent the parachute from deploying during debugging, if you do this there is not a problem checking the operation of the servo.
- The parachute must be folded in accordance with the parachute folding video. It is the responsibility of the user the parachute does not open because it has been improperly folded. Parachute folding

video:http://v.youku.com/v_show/id_XNjgxNTQ1OTU2.html

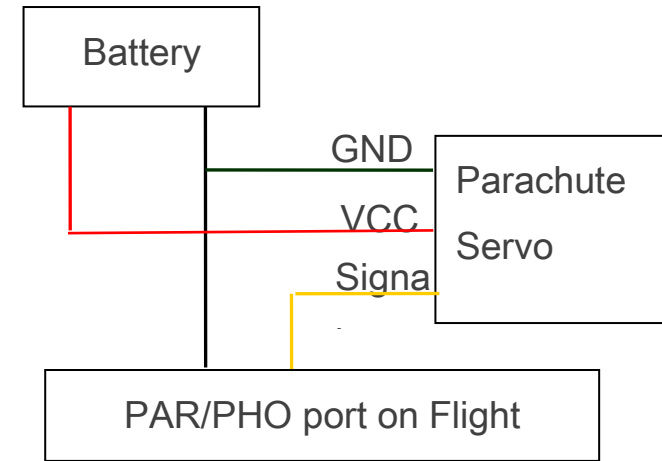

Figure 16 Test Parachute Opening/Closing

3.6.1 Android GCS test

The parachute operation can be tested as follows:

1. Click “Test Open Parachute” in the “Settings” interface to pop up the confirmation dialogue box, as shown in Figure17.
2. Click “OK”, to open the parachute capsule.
3. Click “Test Close Parachute” and click “OK”, as shown in Figure18.

NOTE: The Gimbal controller does not support the parachute.

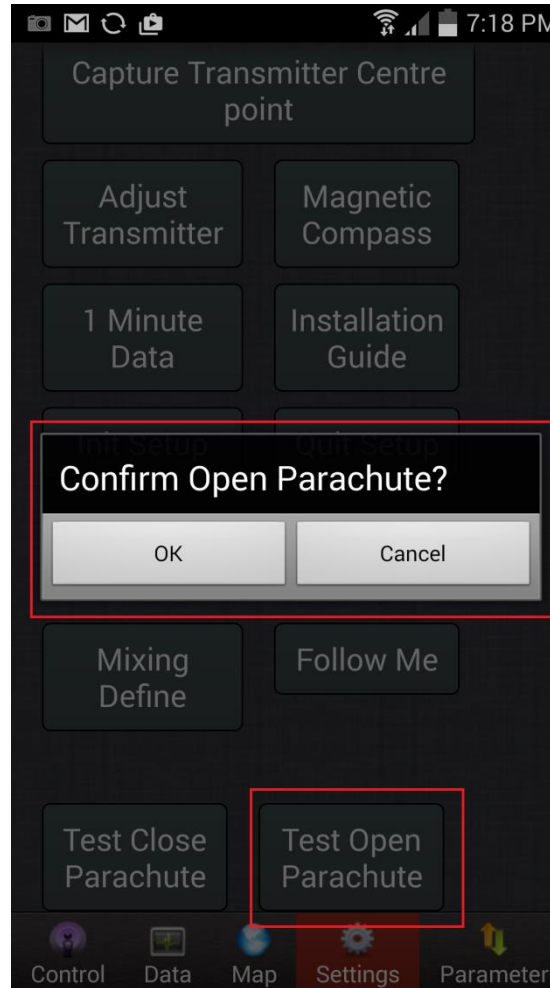

Figure17 Android GCS test-open

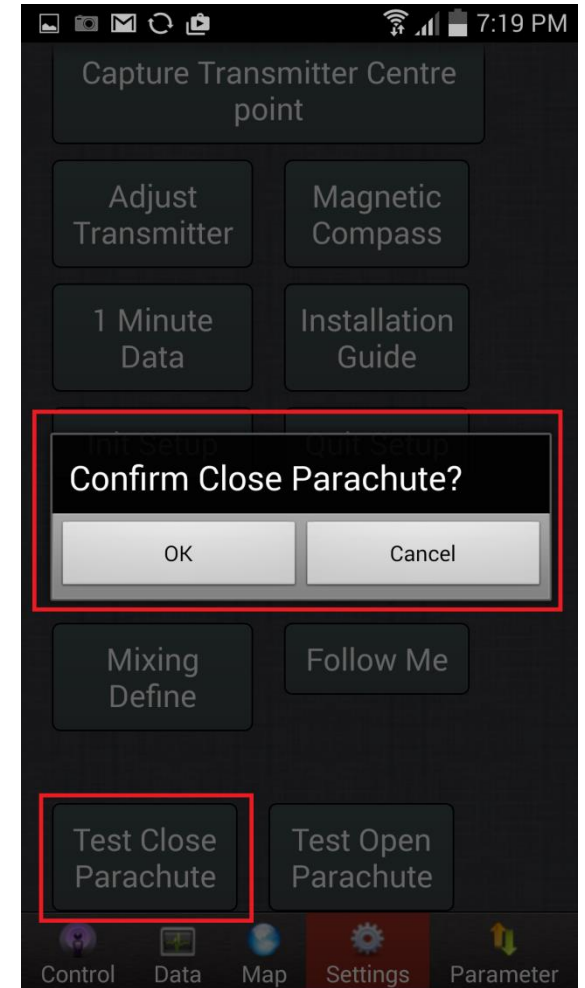

Figure18 Android GCS test-close

3.6.2 PC GCS test

The parachute operation can be tested as follows:

1. Select *settings*→*Test Parachute*→*Open Parachute*, then parachute case open.
2. Select *settings*→*Test Parachute*→*Close Parachute*, then servo close.

NOTE: The Gimbal controller does not support the parachute.

3.7 Calibrating the Magnetic Compass

3.7.1 Using the Android GCS

NOTE:

- The magnetic compass must be calibrated before the first flight after installation of the Gemini flight controller.
- Calibration should be carried out in a clear space outside; calibration should not be done indoors or in an environment with strong magnetic fields, such as in the presence of cars or shipping containers.
- You should also calibrate after re-arranging components in your aircraft or if you find it flies in circles.
- Compass calibration does not need to be done every time you fly, or if you upgrade firmware without changing hardware position. However it should be done when components are moved or if the aircraft flies in unexpected ways.

Compass calibration is carried out in three steps: horizontal calibration, vertical calibration and storage of magnetic compass data. Instructions for each stage can be found in the status bar at the top “Settings” interface, as follows:

1. Switch the transmitter to manual mode and pull the throttle to minimum.
2. Click “Settings” to enter the settings interface, as shown in Figure19.
3. Click “Magnetic compass” to open the calibration dialog box, as shown in Figure20.
4. Select “Horizontal Alignment” and to click “OK” to start horizontal calibration.



Figure19 data interface

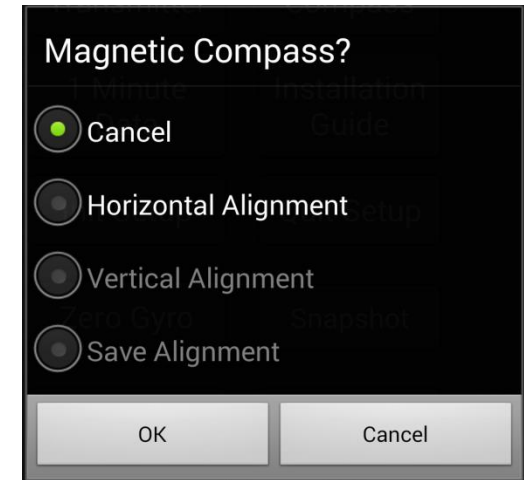

Figure20 Magnetic Compass Calibration Interface

5. **Hold the aircraft horizontally** (within a status error of 5° which can be maintained if you hold the aircraft with both hands),turn around two or three times slowly making sure that the blue LED stays lit. If the blue LED goes off, stop and adjust the aircraft, before continuing.

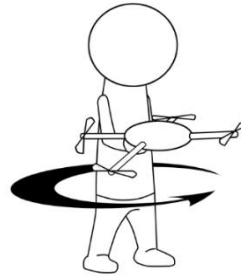

Figure21 Horizontal Alignment

6. Now select “Vertical Alignment” and click “OK” for vertical calibration.
7. **Hold the aircraft with the nose vertically down**(within a status error of 5°) turn around two or three times slowly making sure that the blue LED stays lit. If the blue LED goes off, stop and adjust the aircraft, before continuing.



Figure22 Vertical Alignment

8. Select “Save Alignment” in the dialogue box and click “OK”.
9. You will need to wait for the flight controller to process the recorded magnetic data. A purple LED will show during the processing. When the purple light goes out, calibration is complete. The ground station will switch to the remote control interface automatically and spend a few seconds calculating. Then it will display two circles, **one blue and the other red**, as indicated in the following figures: The superposition of two circles, red and blue indicates successful calibration. If this is not the case you need to start again with a new calibration operation.

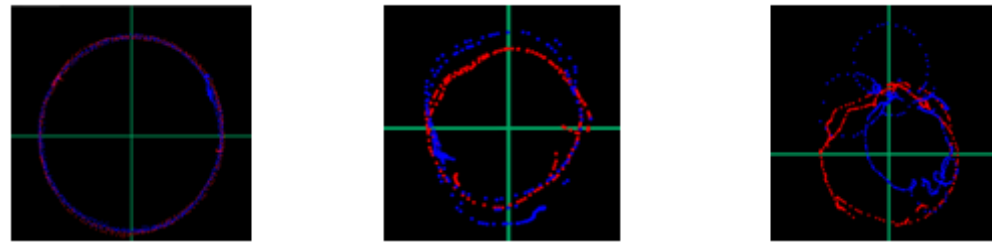

Figure23 figure shows excellent, qualified and disqualification

3.7.2 Compass Calibration Using a PC Ground Station

NOTE:

- The magnetic compass must be calibrated before the first flight after installation of the Gemini flight controller.
- Calibration should be carried out in a clear space outside; calibration should not be done indoors or in an environment with strong magnetic fields, such as in the presence of cars or shipping containers.

- You should also calibrate after re-arranging components in your aircraft or if you find it flies in circles.
- Compass calibration does not need to be done every time you fly, or if you upgrade firmware without changing hardware position. However it should be done when components are moved or if the aircraft flies in unexpected ways.

Compass calibration is carried out in three steps: horizontal calibration, vertical calibration and storage of magnetic compass data. Instructions for each stage can be found in the status bar at the top “Settings” interface, as follows:

1. Switch the transmitter to manual mode and pull the throttle to minimum.
2. Select “Settings(S)” → “Magnetic Compass (M)” for the “Magnetic Compass Alignment” window as shown in Figure24.
3. Click “Horizontal Alignment” for horizontal calibration, as shown in Figure25.

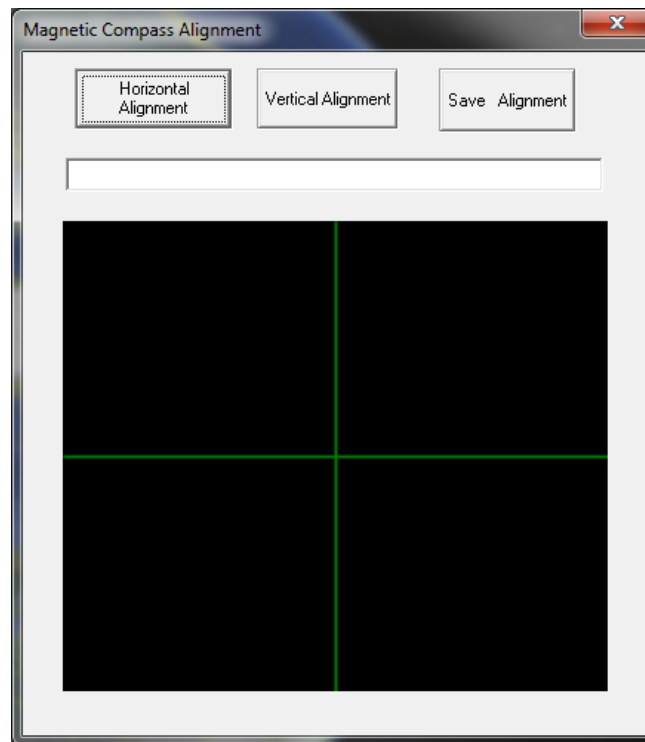

Figure24 Alignment window

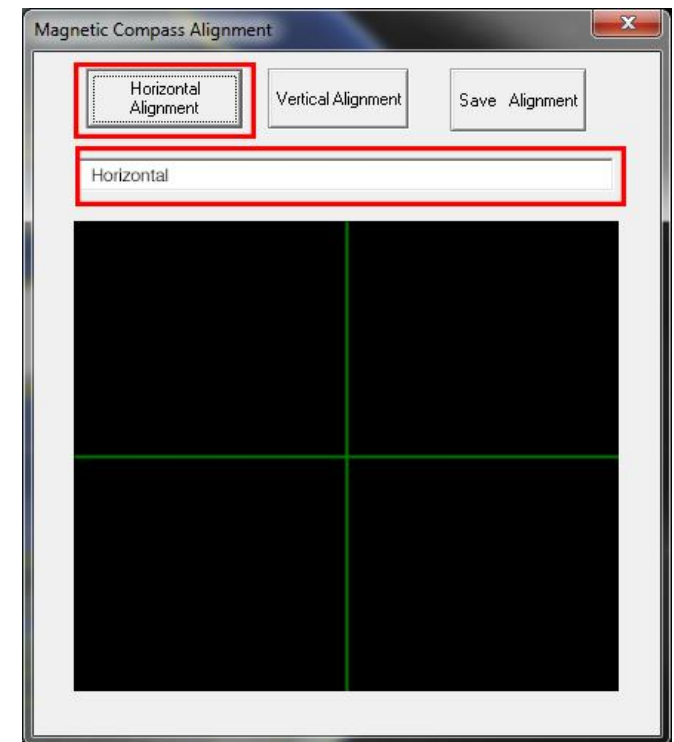

Figure25 Horizontal Alignment

4. **Hold the aircraft horizontally** (within a status error of 5° which can be maintained if you hold the aircraft with both hands),turn around two or three times slowly making sure that the blue LED stays lit. If the blue LED goes off, stop and adjust the aircraft, before continuing.

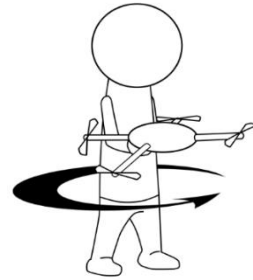

Figure26 Horizontal Alignment

5. Now select “Vertical Alignment” and click “OK” for vertical calibration.
6. **Hold the aircraft with the nose vertically down**(within a status error of 5°) turn around two or three times slowly making sure that the blue LED stays lit. If the blue LED goes off, stop and adjust the aircraft, before continuing.
7. Select “Save Alignment” in the dialogue box and click “OK”.

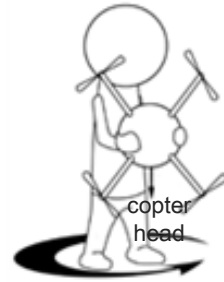

Figure27 Vertical Alignment

8. You will need to wait for the flight controller to process the recorded magnetic data. A purple LED will show during the processing. When the purple light goes out, calibration is complete. The ground station will switch to the remote control interface automatically and spend a few seconds calculating. Then it will display two circles, **one blue and the other red**, as indicated in the following figures: The superposition of two circles, red and blue indicates successful calibration. If this is not the case you need to start again with a new calibration operation.

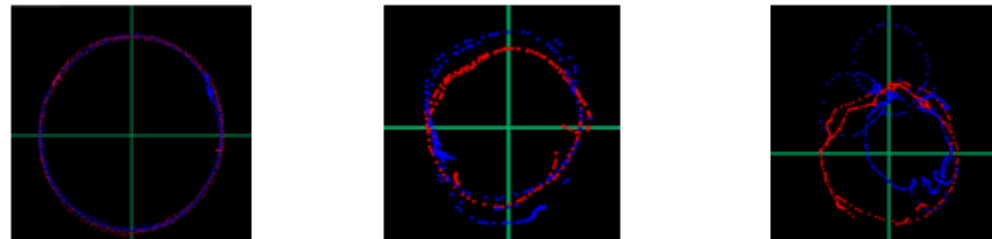

Figure28 figure shows excellent, qualified and disqualification

3.8 How to unlock motors before flight

NOTE:

- In Beijing, if you are in the area inside the 5 ring or near various airports it is not possible to arm the motors using CSC.
- If you arm the motors using CSC, and do not operate the throttle stick within five seconds then the motors will lock again.

You should execute CSC again to unlock the motors.

- Motor arming is not available if CH5 of the aircraft TX is in the middle position.
- Motor arming by CSC is not available if the GPS compass and the actual compass bearing differs by more than 15°.
- The parachute must be folded strictly in accordance with the instructional video. It is the user's responsibility should the parachute fail to deploy. A video showing how to fold the parachute is available here (take HighOne for example) :

http://v.youku.com/v_show/id_XNjgxNTQ1OTU2.html

These steps should be followed before unlocking the motors for flight:

1. Before takeoff, make sure the parachute is folded and placed in its container correctly.

NOTE :Operation of the parachute can be tested using the android ground station. When commissioning press the lid of the container so that the parachute cannot pop out. It's operation can now be checked. For more detailed instructions see the Gemini Flight Control Manual.

2. Check failsafe is working. Before each flight this must be checked otherwise it will not be possible to start the motors using the CSC.

- 1) Check the throttle is in mid-position. Switch off the aircraft remote control.

- 2) The flight status on the ground station should be reported as "return to land." If not failsafe (F/S) should be set up again.

On the Android ground station: check in the "data" section.

On a PC ground station: select "view" → "dashboard," check on the right side of the dashboard.

- 3) Power up the remote control.

- After unlocking using CSC, slightly push the throttle. Check that motor mixing is normal. According to your transmitter mode (Mode 1, Mode 2, Mode 3, etc.) when executing the CSC the sticks can be moved in a “V” shape or a “Λ” shape. Take the “Λ” shape as an example; the throttle stick should be reduced to the minimum and pushed to the left, the elevator stick should be reduced to the minimum and pushed to the right. This example would apply to a Mode 2 transmitter (American standard)
- The Gemini ground station can monitor the state of two sets of independent sensors at the same time, when the user observes that at least seven satellites are in view of the GPS it is possible to arm the motors and take off.

NOTE: If remote controller can't be unlocked, please do the following checking: remote controller should be closed when checking the newest firmware (F/S setting correctly, CH5 and CH6 are on position 3, throttle is in the middle position). Combination stick command after checking and then motor will start, otherwise it refused. It needn't to be checked again except energizing. But it should be checked again when power is disconnected. It also should be checked again to the remote controller settings

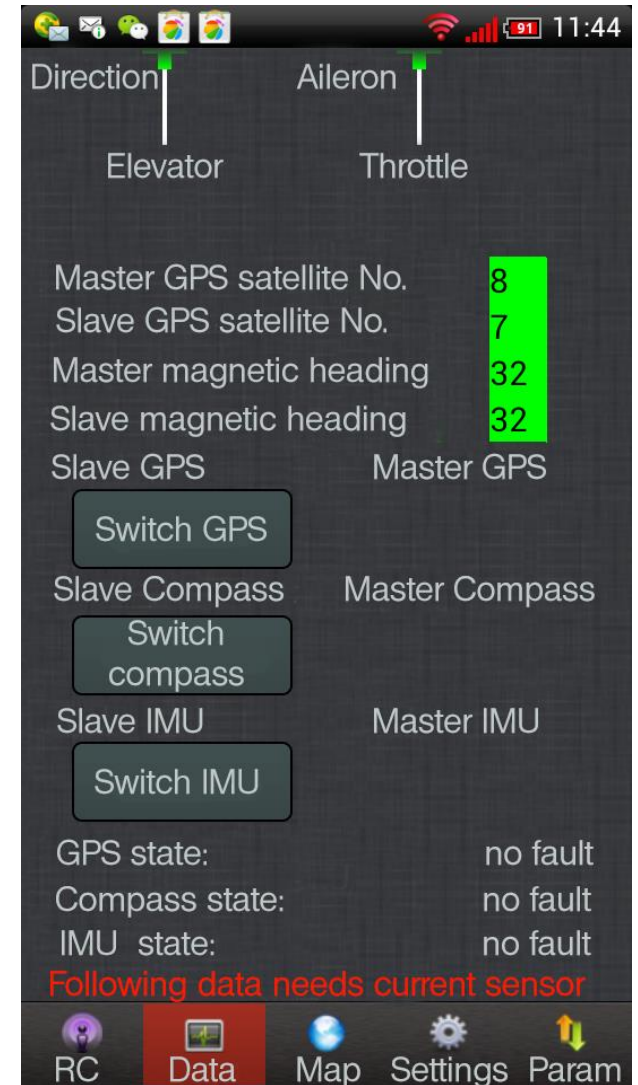

Figure 29 GCS- satellites

4 Flight operation (Important)

4.1 Careful attention during flight

a. Before taking off, check that the following parameters are all reported as normal by the ground station data section:

"motor balance" "actual accelerator rudder", "magnetic compass", GPS and IMU.

– When there is no wind the aircraft should maintain position automatically and the "motor balance" being displayed as "good" for most of the time would be regarded as normal.

– The value of "actual accelerator rudder" should display around 50.

– Magnetic compass, GPS and IMU should be in "no failure" status, the GPS satellite number should be 7 or more, and the difference between the magnetic heading of this machine and the actual magnetic heading angle should not exceed 15°.

b. The HighOne-Pro leaves the factory with the default values in the controller. If you wish to restore default values after changing any parameters you can do so in the ground station.

- On an Android ground station: click the "default" button in the "parameter" interface.
 - On a PC ground station: select "settings" → "parameter setting", pop out the parameter setting window and click the "restore default" button.
- c. For safety reasons, when in settings status it is not possible to start the motors.
- d. It is only possible to exit return-to-land mode after switching back to manual operation.
- e. Do not reduce the throttle to minimum when in manual flying mode. Doing so will cause the motors to stop and the aircraft to crash.
- f. If the aircraft is not stable in manual mode do not switch to GPS mode as this will make it even more unstable.

NOTE:

- According to your preference you can select to use a single remote control or two remote controls to operate. The method for switching between these modes is explained at step 6 in "Energizing".
- This manual is only aimed at introducing for professionals, the Zero UAV Z-series gimbals. For other basic flight operations please refer to the **Gemini flight control manual**

4.2 LED Status Indications

❖ **RED+BLUE** (or **GREEN**) LED——indicating the current operational state of the aircraft

Light colour	Light status	Operational status
Red light (for all modes)	3 flashes •••	No GPS
	2 flashes ••	GPS 5 satellites
	1 flash •	GPS 6 satellites
	Red light out	GPS 7 or more satellites
Blue light (GPS mode, non-positioning)	2 flashes ••	Hovering at fixed height
	1 flash •	User in operation
Green light (GPS mode, in positioning)	2 flashes ••	Hovering at fixed point
	1 flash •	User in operation

NOTE : Only take off after 7 or more GPS satellites are in view. The flight controller will use the take-off position as the home location when the GPS first locks in to seven satellites.

❖ **White LED**——indicating a large status error or a loose connection to the GPS module

Action required when the white light comes on:

- If the light comes on when the aircraft is suffering violent movement but goes out when it retains stability than you can continue the flight normally.
- Land the aircraft as soon as possible if the white light shows continuously and check the GPS connection. Zero the gyro in the GCS if there is a status error.

❖ **RED LED**——Low voltage alarm

- The red light will flash quickly as a low battery voltage alarm. It shows as a solid light in an emergency situation of extreme low voltage.
- A continuous red light showing when the aircraft is on the ground, indicates the failure of the barometer to initialize. You must restart the flight controller.

❖ **BLUE+PURPLE LED**——Magnetic field verification

- When calibrating, a continuous blue light indicates a magnetic compass calibration error less than 5° and indicates a successful calibration. However, if the blue light goes off with a status error more than 5° this indicates that adjustment is needed.
- The purple light will be on continuously when storing the data after calibration of the magnetic data. The purple light will go out completely when data storage is complete.

4.3 Flight mode

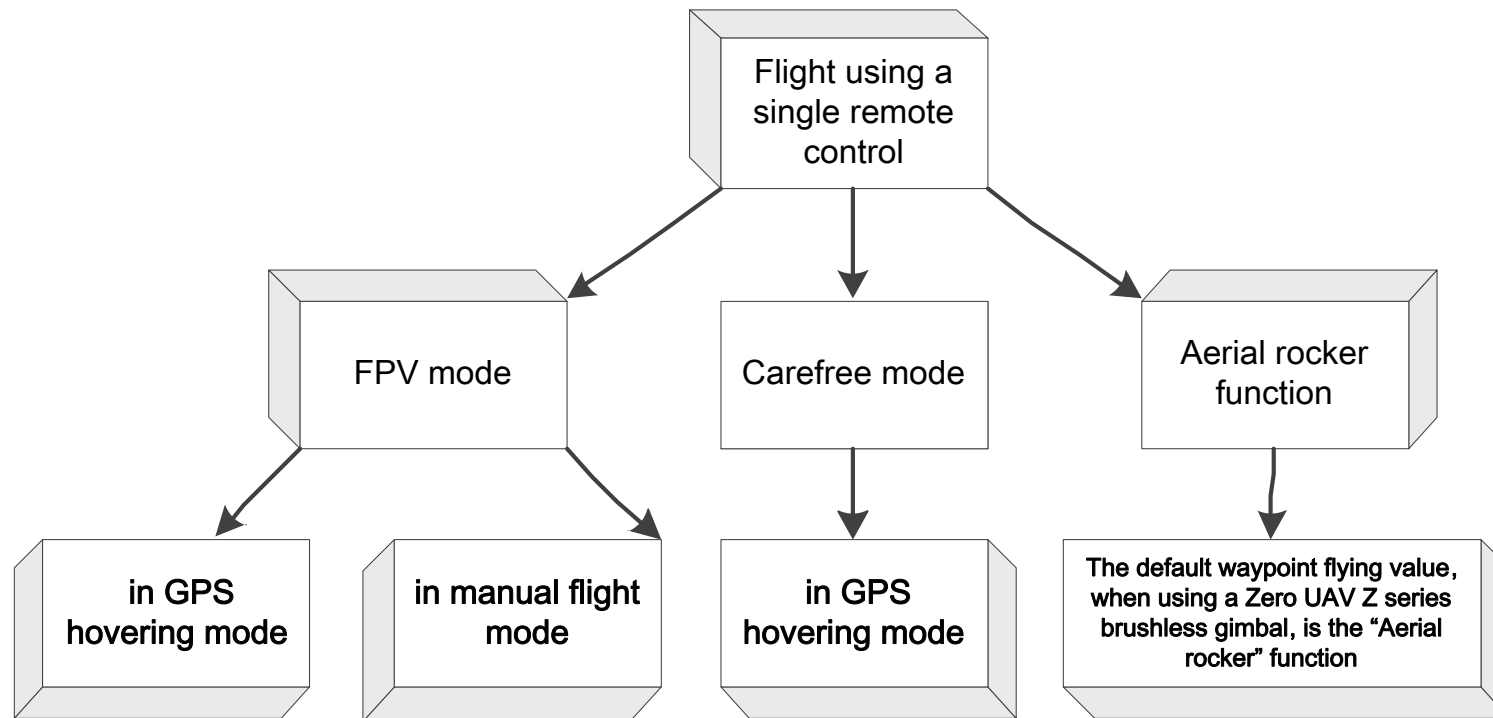

Figure 30 Flight using a single remote control

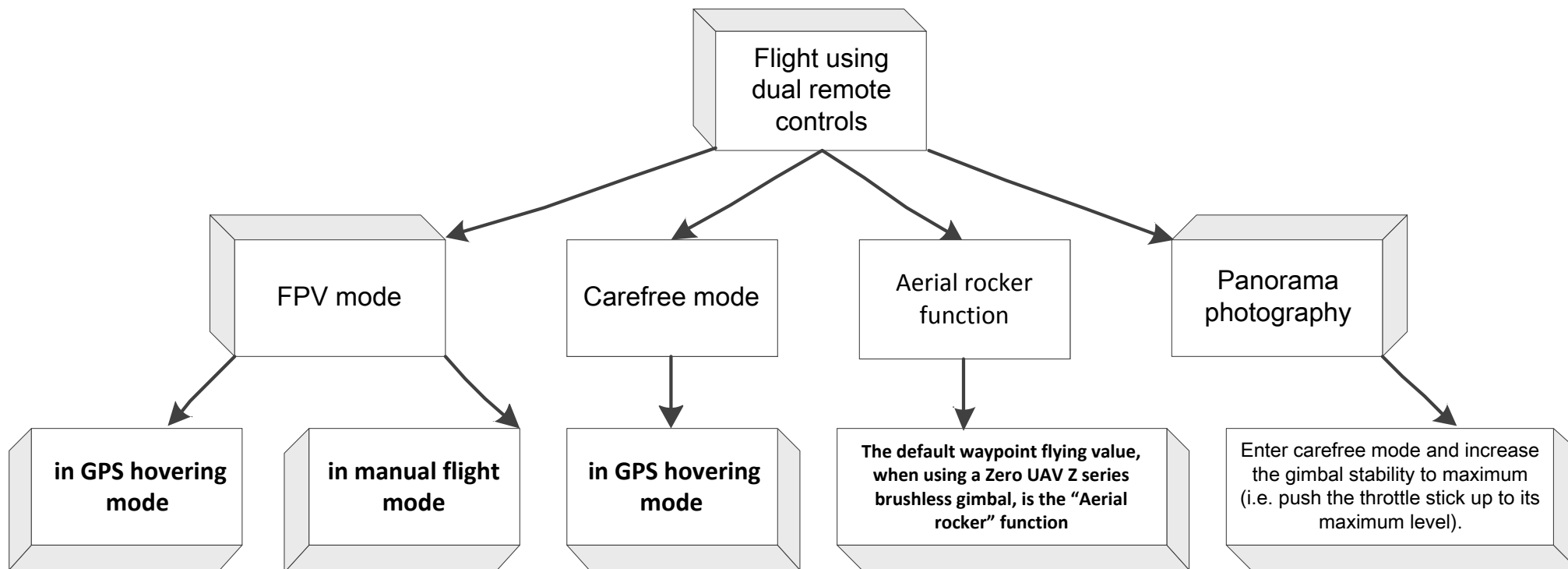

Figure 31 Flight using dual remote controls

4.4 Flight using a single remote control

When operating the equipment using a single remote control, gimbal tilt should be controlled using the CH7 channel lever on the aircraft remote control.

4.4.1 FPV mode

FPV mode (first person view) the aircraft remote control controls the direction of the gimbal. The aircraft heading

automatically follows the direction of the gimbal so as to avoid the landing gear from blocking the view of the camera. The pitch and roll of the aircraft will follow the video direction as reference. For example, when circling a point of interest, the pilot can always focus on the target by just using the rudder. The autopilot will control aileron, elevator, height and distance.

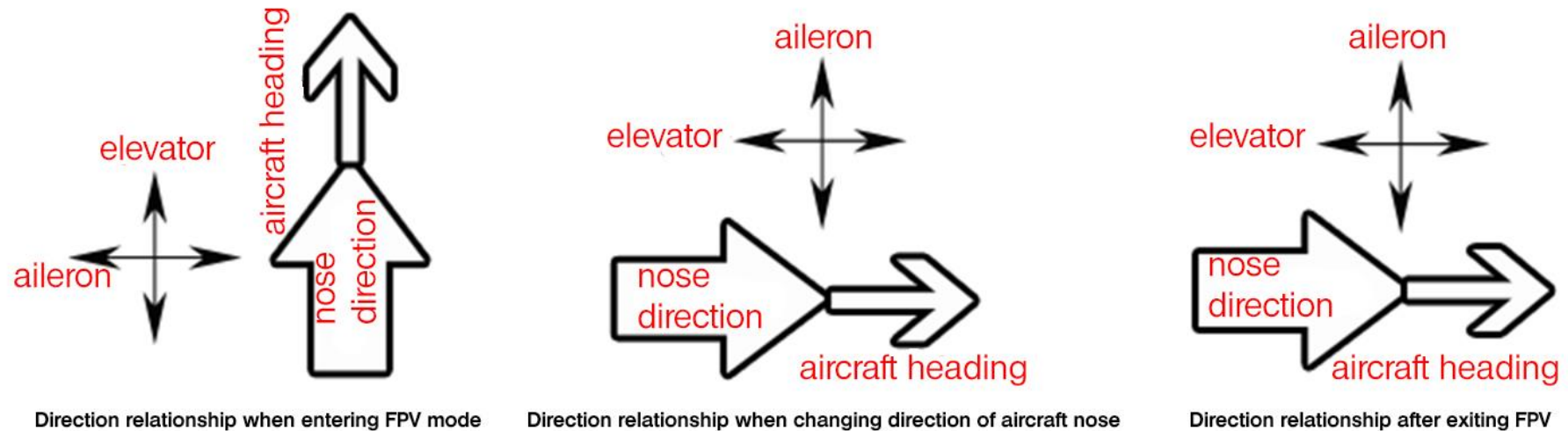

Figure 32 Single remote control-FPV mode

❖ **FPV operation in GPS hovering mode**

1. After the aircraft enters hover in GPS mode, switch CH5 from position 3 to position 2, after a 2 second pause the aircraft will enter FPV mode with a high level of stability. The aircraft will remain hovering in GPS mode at that moment.
2. To leave FPV mode switch CH5 back to the first position for manual mode or 3rd position for GPS hover.

The status of all parameters in FPV mode is shown in following table.

Flight mode	Flight course	Aircraft head	Remote controlling instruction	Aircraft remote control	
				Aircraft	Gimbal
Highly stable FPV mode	Takes gimbal direction as reference	The aircraft head direction always follows the direction of the camera lens.	Rudder	Not controllable	Controllable
			Aileron rudder	Controllable	Not controllable
			Elevator	Controllable	Not controllable
			Accelerator rudder	Controllable	Push throttle stick to increase stability
			CH5	Position two	
CH6	Position one				

NB. Gimbal tilt is controlled by CH7.

❖ **FPV operation in manual flight mode**

1. After the aircraft takes off in manual, place CH5 from position 1 to position two. After a 2 second pause the aircraft will

enter FPV mode with a high level of stability. **Unlike when in GPS automatic hover status, the aircraft will remain in manual mode..**

2. To leave FPV mode, switch CH5 back to the first position for manual mode.

The status of all parameters in manual mode is shown in following table.

Flight mode	Flight course	Aircraft head	Remote controlling instruction	Aircraft remote control	
				Airplane	Gimbal
Highly stable FPV mode	Takes gimbal direction as reference	The aircraft head direction always follows the direction of the camera lens.	Rudder	Not controlled	Controlled
			Aileron rudder	Controlled	Not controlled
			Elevator	Controlled	Not controlled
			Accelerator rudder	Controlled	Push throttle stick to increase stability
			CH5	Position two	
			CH6	X	
NB. Gimbal tilt is controlled by CH7.					

4.4.2 Carefree mode (only for GPS Hover Status)

This mode must be used in GPS Hover Status. In carefree mode, the navigation direction of the aircraft is locked (i.e. the direction the aircraft is heading when entering this mode). Whatever direction faced by the nose of the aircraft, the flight direction will remain unchanged. The nose of the aircraft automatically keeps track of the gimbal so that the camera avoids the landing gear. The elevator and aileron of the aircraft take the navigation direction of the aircraft as reference.

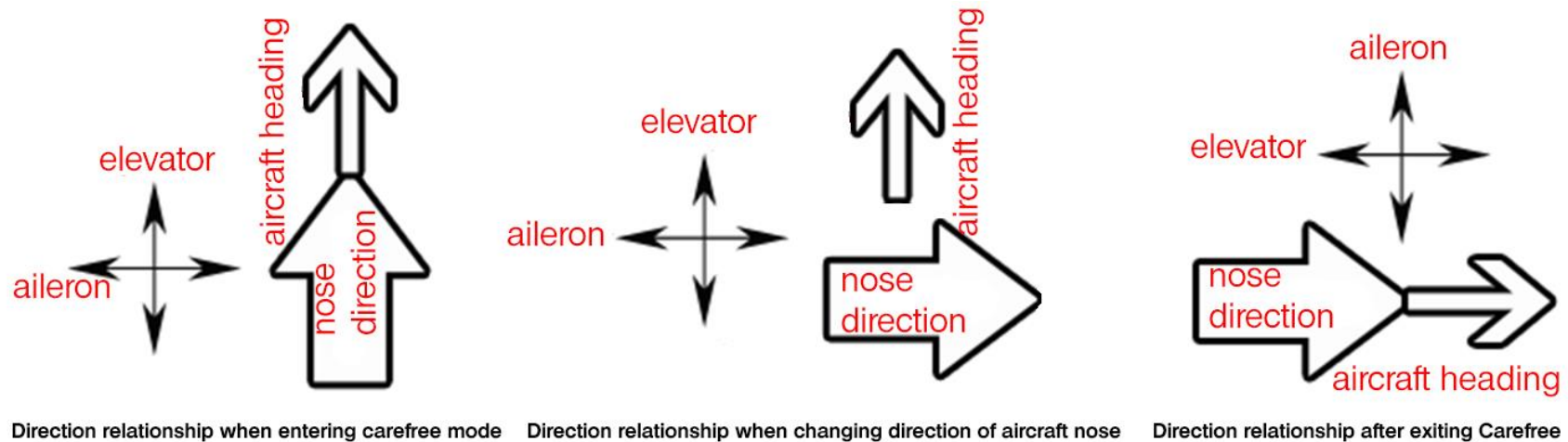

Figure 33 Single remote control-carefree mode

Enter carefree mode as follows:

1. Switch to GPS mode after take-off, the aircraft will hover as normal.

2. After selecting the desired flight direction align the nose of the aircraft in this direction. Switch CH5 from position 3 to position 2, switch back to position 3 then return to position 2. You will now be in carefree mode.
3. When you need to exit carefree mode, switch channel 5 to position 1 or position 3 (manual mode or GPS mode).

The status of all parameters in carefree mode is shown in following table.

Flight mode	Flight course	Aircraft head	Remote controlling instruction	Aircraft remote control	
				Airplane	Gimbal
carefree	Take user selected direction as reference	The aircraft head direction always follows the direction of the camera lens.	Rudder	Not controllable	Controllable
			Aileron rudder	Controllable	Not controllable
			Elevator	Controllable	Not controllable
			Accelerator rudder	Controllable	Push throttle stick to increase stability
			CH5	Position two	
			CH6	Position one	

NB. Gimbal tilt is controlled by CH7.

4.4.3 Aerial rocker function

The default waypoint flying value, when using a Zero UAV Z series brushless gimbal, is the “Aerial rocker” function. Rocking the elevator stick backwards and forwards controls the speed of waypoint flight.

When in the aerial rocker function, the aircraft remote control controls the direction of gimbal, the aircraft head tracks the gimbal direction. Pushing the elevator stick will make the aircraft fly according to the scheduled way point route; the greater the degree of elevator input the higher the flight speed. Releasing the stick to centre will make the aircraft return to hover.

After complete all way points, releasing the stick to centre will cause the aircraft to return to the 1st way point and hover.

Enter the aerial rocker function as follows:

1. Setup your waypoint route on the GCS map interface, upload the route to the autopilot and verify.
2. After takeoff, switch to GPS mode and hover.
3. Switch CH6 from position 1 to position 2. Pause for five seconds and the aerial rocker function will enable.
4. To exit, return CH5 to position one (manual mode) or CH6 to position one (GPS mode).

The status of all parameters in aerial rocker mode is shown in following table.

Flight mode	Flight course	Aircraft head	Remote controlling instruction	Aircraft remote control	
				Airplane	Gimbal
Aerial rocker (waypoint route)	Direction of planned route	Head direction always follows the direction of the camera lens.	Rudder	Not controllable	Controllable
			Aileron rudder	Not controllable	Not controllable
			Elevator	Regulates speed of waypoint flight	Not controllable
			Throttle rudder	Not controllable	Push throttle stick to increase stability
			CH5	Position three	
			CH6	Position two	

NB. Gimbal tilt is controlled by CH7.

4.5 Flight using dual remote controls

4.5.1 FPV mode

FPV mode (first person view) the aircraft remote control controls the direction of the gimbal. The aircraft heading automatically follows the direction of the gimbal so as to avoid the landing gear from blocking the view of the camera. The pitch and roll of the aircraft will follow the video direction as reference. For example, when circling a point of interest, the pilot can always focus on the target by just using the rudder. The autopilot will control aileron, elevator, height and distance.

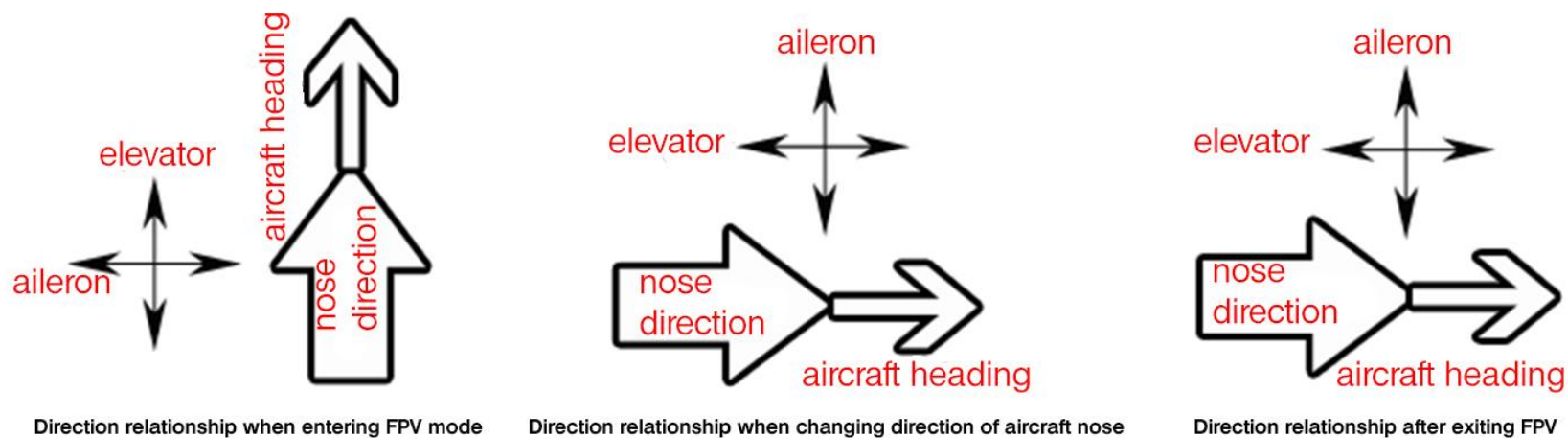

Figure 34 Dual remote controls-FPV mode

❖ **FPV operation in GPS hovering mode**

1. Switch CH5 of the gimbal remote control to position 1, the gimbal will not be in tracking mode.
2. After the aircraft enters hover in GPS mode, switch CH5 on the aircraft controller from position 3 to position 2, after a 2 second pause the aircraft will enter FPV mode with a high level of stability. **The aircraft will remain hovering in GPS mode.**
3. To leave FPV mode switch CH5 on the aircraft controller back to the first position for manual mode or 3rd position for GPS hover.

The status of all parameters in FPV mode is shown in following table.

Flight mode	Flight course	Aircraft head	Remote controlling instruction	Aircraft remote control	Gimbal remote control
Highly stable FPV mode	Takes gimbal direction as reference	The aircraft head direction always follows the direction of the	Rudder	Controllable	Not controllable
			Aileron rudder	Controllable	Roll is controllable
			Elevator	Controllable	Pitching is controllable
			Accelerator rudder	Controllable	Push throttle stick to

		camera lens.			increase stability
			CH5	Position two	Position one
			CH6	Position one	X
NB: When CH6 is shown as X changing the sensitivity of the gimbal will be invalid.					

❖ **FPV operation in manual flight mode**

1. Switch CH5 of the gimbal remote control to position one; the gimbal will not be in tracking mode.
2. After the aircraft takes off in manual, place CH5 from position 1 to position two. After a 2 second pause the aircraft will enter manual FPV mode with a high level of stability. Unlike when in GPS automatic hover status, the aircraft will remain in manual mode.
3. To leave FPV mode switch CH5 back to the first position for manual mode.

The status of all parameters in manual mode is shown in following table.

Flight mode	Flight course	Aircraft head	Remote controlling instruction	Aircraft remote control	Gimbal remote control
Highly stable	Take gimbal	The aircraft head	Rudder	Controllable	Not Controllable

FPV mode	direction as reference	direction always follows the direction of the camera lens..	Aileron rudder	Controllable	Roll is Controllable
			Elevator	Controllable	Pitch is controllable
			Accelerator rudder	Controllable	Push throttle stick to increase stability
			CH5	Position two	Position one
			CH6	X	X

4.5.2 Carefree mode

This mode must be used in GPS Hover Status.

In carefree mode, the navigation direction of the aircraft is locked (i.e. the direction the aircraft is heading when entering this mode). Whatever direction faced by the nose of the aircraft, the flight direction will remain unchanged. The nose of the aircraft automatically keeps track of the gimbal so that the camera avoids the landing gear. The elevator and aileron of the aircraft take the navigation direction of the aircraft as reference.

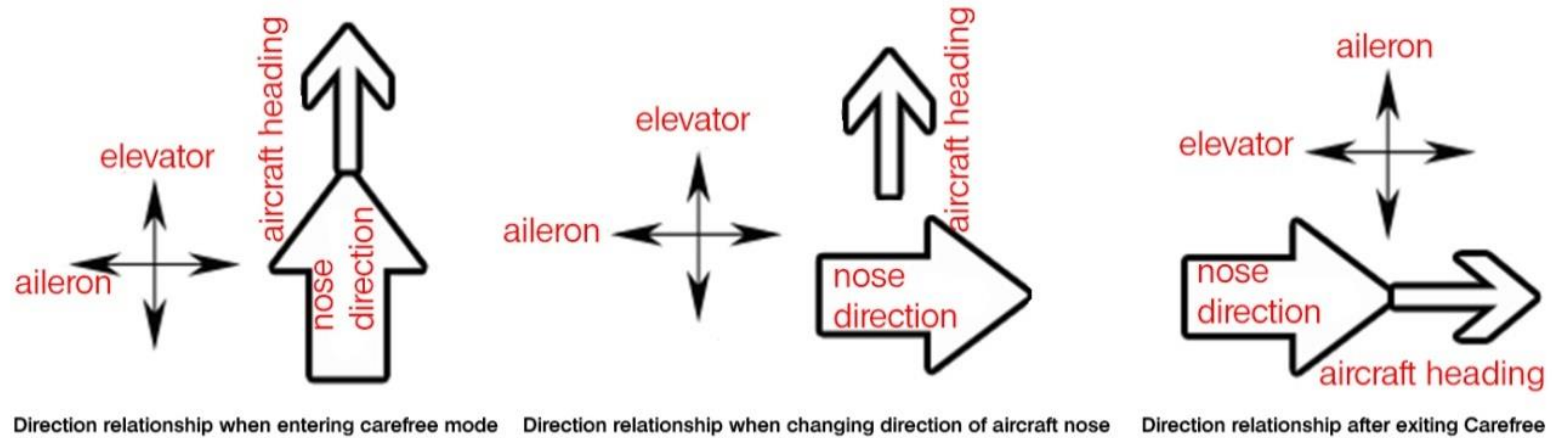

Figure 35 Dual remote controls-carefree mode

Enter carefree mode as follows:

1. Switch CH5 of the gimbal remote control to position one; the gimbal will not be in tracking mode.
2. After takeoff switch to GPS mode and hover.
3. After selecting the desired flight direction align the nose of the aircraft in this direction. Switch CH5 on the flight controller from position 3 to position 2 , switch back to position 3 then return to position 2. You will now be in carefree mode.
4. When you need to exit carefree mode, switch channel 5 to position 1 or position 3 (manual mode or GPS mode).

The status of all parameters in carefree mode is shown in following table.

Flight mode	Flight course	Aircraft head	Remote controlling instruction	Aircraft remote control	Gimbal remote control
Carefree	Take user selected direction as reference	The aircraft head direction always follows the direction of the camera lens..	Rudder	Controllable	Direction is Controllable
			Aileron rudder	Controllable	Roll Controllable
			Elevator	Controllable	Pitching Controllable
			Accelerator rudder	Controllable	Push throttle stick to increase stability
			CH5	Position two	Position one
CH6	Position one	X			

4.5.3 Aerial rocker

The default waypoint flying value, when using a Zero UAV Z series brushless gimbal, is the aerial rocker function. Rocking the elevator stick backwards and forwards controls the speed of waypoint flight.

When in the aerial rocker function, the gimbal remote control controls the direction of gimbal, the aircraft head tracks the gimbal direction. Pushing the elevator stick will make the aircraft fly according to the scheduled way point route; the greater the degree of elevator input the higher the flight speed. Releasing the stick to centre will make the aircraft return to hover. After completing all way points, releasing the stick to the centre will cause the aircraft to return to the first way point and hover.

Enter the aerial Rocca function as follows:

1. Setup your waypoint route on the GCS map interface, upload the route to the autopilot and verify.
2. After takeoff, switch to GPS mode on the aircraft controller and hover.
3. Switch CH6 on the aircraft controller from position 1 to position 2. Pause for five seconds and the aerial rocker function will enable.
4. To exit, return CH5 to position one (manual mode) or CH6 to position one (GPS mode).

The status of all parameters in aerial rocker mode is shown in following table.

Flight mode	Flight course	Aircraft head	Remote controlling instruction	Aircraft remote control	Gimbal remote control
Aerial rocker (waypoint route)	Direction of planned route	Head direction always follows the direction of	Rudder	Not controllable	Direction is controllable
			Aileron rudder	Not controllable	Roll is controllable

		the camera lens.	Elevator	Regulates speed of waypoint flight	Pitch is controllable
			Accelerator rudder	Not controllable	Push throttle stick to increase stability
			CH5	Position three	Position one
			CH6	Position two	X

4.5.4 Panorama photography

Panorama photography is only possible when using two remote controls. Panorama photography makes it possible to completely automate specific photography functions such stay level, pitch down 30°, pitch down 60°, pitch down 90°, taking four photographs at each level (12 photos for the first 3 layers, 1 one photo for last layer making 37 copies in total).

Panorama photography operation is as follows:

1. Enter carefree mode and increase the gimbal stability to maximum (i.e. push the throttle stick up to its maximum level).
2. Switch CH6 channel on the gimbal remote control from position 1 to position three rapidly 3 times continuously

(1→3→1→3→1→3→1) this will initiate automatic panorama photography.

3. In panorama photography mode, the aircraft will pan automatically and the gimbal direction will keep consistent with the direction of aircraft. The gimbal will automatically control the camera to place it in the various attitudes needed for panorama photography.
4. After completion of the panorama sequence, the gimbal will automatically return to its level position. (The last photo will be taken with the camera pointing vertically downwards at 90°) The aircraft will now hover. To exit the panorama function, switch to manual mode.



4.6 Landing



During flight, staff monitoring the ground station should, at all times, keep an eye on the flight pack voltage, the balance performance of the motors, the number of GPS satellites in view and the flight time so as to be able to remind the pilot to land in good time. After landing, carry out the following operations:



1. Reduce the throttle stick on the gimbal remote-control to its lowest position, the gimbal will stop stabilizing.
2. Remove the power supply and by hand feel each motor to feel if any have heated more than the others. If the temperature difference is too large, it is an indication that the motor is not installed horizontally.

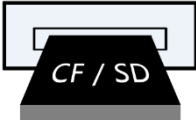

5 Introduction to Functions

Graphical presentation	Functions	Introduction
	<p style="text-align: center;">Combined with Zero UAV professional flight control.</p> <p>The HighOne-Pro system is integrated with a Gemini autopilot which consists of duplicated control units, the Master Controller and a Slave Controller. Each has its own IMU (Inertial Measurement Unit) which includes 2 separate sets of gyros, accelerometers, and barometric sensors. There are also two GPS/COMPASS units. Having everything duplicated ensures maximum safety and reliability. If any unit associated with flight control fails or loses control then the system automatically switches to a functioning unit. The ground station continually monitors the status of two Controllers, and warns the user whenever a unit has failed and the other has switched in. This built-in redundancy greatly increases</p>	<p>Please refer to</p> <p style="text-align: center;"><i>Gemini (dual redundancy)</i></p> <p style="text-align: center;"><i>Autopilot Manual</i></p>

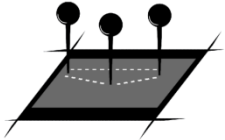
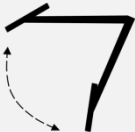
	<p>safety, stability and reliability and minimizes the likelihood of accidents.</p>	
	<p align="center">Matches the Zero UAV high-end gimbal</p> <p>Combined with the newest ZERO brushless gimbal, the Z1400, the aircraft is able to keep the camera completely level and stable, regardless of flying conditions. This high-precision camera attitude correction achieves impressive filming stability.</p>	<p>Please refer to <i>Z1400 High -End Gimbal User Manual</i></p>
	<p align="center">Security parachute supported</p> <p>So as to fully ensure the safety of expensive camera equipment, Zero UAV has designed a innovative, dedicated security parachute for the whole system which automatically deploys in emergency. It is the 2nd tier of security, the first being the dual redundancy of the AP.</p>	<p>Please refer to <i>Gemini(dual redundancy) Autopilot Manual</i></p>
	<p align="center">Single or dual controllers supported</p> <p>The HighOne-Pro system supports both single transmitter control (one transmitter controls the aircraft and gimbal pitch at the same time) and dual</p>	<p>Please refer to 4.4 and 4.5</p>

	<p>transmitter control (one transmitter controls the aircraft whilst the other transmitter controls the roll, pitch and yaw of the gimbal). The dual control method simplifies flying.</p>	
	<p style="text-align: center;">Highly stable FPV mode</p> <p>The ZERO UAV professional autopilot works in conjunction with the gimbal controller to produce a highly stable FPV mode. In this mode the aircraft course heading automatically follows the gimbal heading. The elevator and aileron controls of the RC transmitter are relative to the coordinates of the gimbal. This simple operation ensures stable video and is very convenient for both the cameraman and the pilot.</p>	<p style="text-align: center;">Please refer to 4.4.1 and 4.5.1</p>
	<p style="text-align: center;">360° panoramic photography</p> <p>When flying in “carefree” mode the pilot can utilize the fully automatic panoramic photography function. Using this function, four layers of HD photo in a 360° circumference can be taken in one minute (37 frames in total!) The panorama</p>	<p style="text-align: center;">Please refer to 4.5.4</p>

	<p>can be processed by simple splicing.</p>	
	<p>“Aerial Rocker Arm” function</p> <p>An “Aerial Rocker Arm” function is available where the aircraft can, under auto-pilot, fly a preset route whilst the camera automatically takes pictures according to a programmed sequence. The pilot can vary the speed of flight with just one stick on the remote control.</p>	<p>Please refer to 4.5.3</p>
	<p>Landing gear retracts supported</p> <p>The HighOne-Pro can utilize high strength, high load bearing retractable landing gear which can be easily assembled and deployed using the double remote control option.</p>	<p>Please refer to 6.2.5</p>
	<p>Remote control of photo or video acquisition</p> <p>Camera mode, should be set before take-off , during flight, CH8 of the remote control can be used to switch between photo or video control.</p>	<p>Please refer to 3.4</p>

	<ul style="list-style-type: none"> – When the camera is in photography mode (video), CH8 is used to control the start and stop of recording. – When the camera is in shooting mode (photo), CH8 can be used to control shooting, one picture will be taken on each CH8 command. 	
	<p style="text-align: center;">Small and convenient</p> <p>Because of its small size, folding frame and specially customized metal box , the HighOne-Pro system occupies a very small volume bringing a high level of convenience to the photographer.</p>	<p>Please refer to 3.1</p>
	<p style="text-align: center;">S - BUS conversion module</p> <p>The S-BUS conversion module can used to connect to most of the market PCM or 2.4GHz receiver equipment. It is simple and allows a wide range of radio equipment to be used with the HighOne-Pro.</p>	<p>Connect to S-BUS interface of Master Controller and then could be used.</p>

6 System Introduction

6.1 Parameters

General	Diagonal Wheelbase	770mm
	Weight	4kg
	Max Takeoff Weight	9.5kg
	Motor Type/KV	6210/380KV
	Drive PWM Frequency	400Hz
	Propeller Size/Material	18×5.5inch /Carbon Fibre
Gimbal	Gimbal Type	Z1400 (GH3/GH4)
	Camera Supported	Panasonic GH3/GH4
	Lens Supported	Lumix G 14mm f/2.5 Lumix G 20mm/F1.7 Panasonic LEICA 25/1.4

		OLYMPUS M.ZUIKO DIGITAL ED12mm f/2.0
	Gimbal Features	360 degree panoramic shooting; auto dodging landing gear; Multiple lens supported; Directly insert and get the SD card; Dual Operation and Single operation supported
Control Requirements	Tx Supported (FC and Gimbal)	PCM or 2.4GHz , 7 channels at least (Notice: all channel's F/S supported)
	Receiver Supported (FC and Gimbal)	S-Bus & Common receiver
Flying Parameters	Hovering Accuracy (in GPS mode)	Vertical direction: $\pm 0.5m$, Horizontal: $\pm 1.5m$
	Hovering Time	With Parachute: 12min (21.6V) Without Parachute: 15min 30s (21.6V)
	Flying safety function	Manual deployment parachute; Automatic deployment parachute in emergency; Gemini dual redundancy autopilot; Fail/Safe

6.2 Composition

The HighOne-Pro system is composed of a ground station, a remote control, a remote control system and an airframe equipment. The ground station and airframe exchange data via the remote control system.

Description:

- A Wi-fi module is provided to transmit flight telemetry. The remote control and receiver (RC system) must be provided by the user.
- Ground station only comprises software for Android or PC. A PC or mobile Android device must be provided by the user.

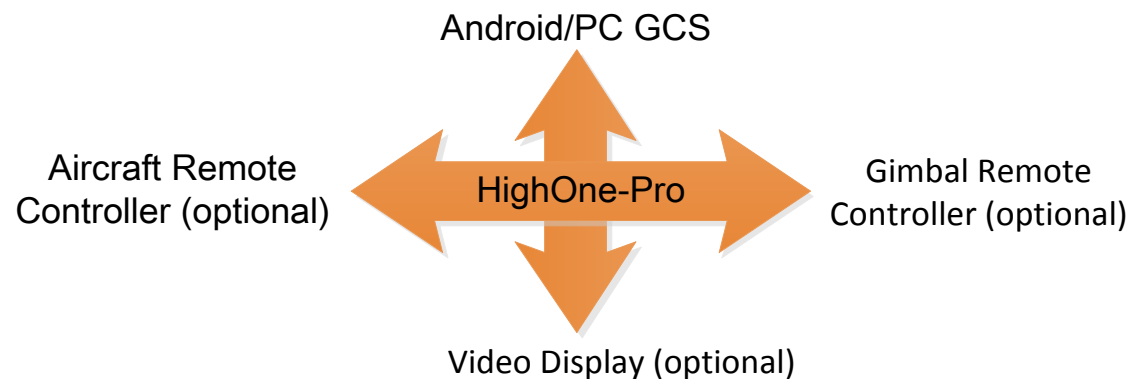

Figure 36 HighOne-Pro Composition

6.2.1 Flight control

Dual redundancy design is applied to flight control of the HighOne, which includes 2 sets of GPS, each of which has a COMPASS and an IMU.

The ground station software can simultaneously monitor the status of 2 sets of independent sensors. If there is any deviation or error on either sensor, the software will automatically switch to another set of sensors so as to continue working correctly improving system navigation and heading control stability.

You should read the [Gemini Autopilot User Manual](#) to familiarize yourself with the Gemini before first use.

❖ Port Definitions: Gemini M flight controller

Port	Port function	Port	Port function
M1	ESC for Motor #1	PTZ1	Gimbal PTZ1 (Servo)
M2	ESC for Motor #2	PTZ2	Gimbal PTZ2 (Servo)
M3	ESC for Motor #3	PTZ3	Gimbal PTZ3 (Servo)
M4	ESC for Motor #4	PAR/PITCH	Parachute or Gimbal Tilt control
M5	ESC for Motor #5	PHO/ROLL	Camera shutter release or gimbal roll

			control
M6	ESC for Motor #6	EXT1	EXT1 to EXT1 on Gemini S
M7	ESC for Motor #7	S-BUS	Connect S-BUS receiver
M8	ESC for Motor #8	EXT2	EXT2 to EXT2 on Gemini S
COM	Wi-Fi data unit or to PC via USB for updating firmware etc.	AI1	Power management module (option)
LED	LED indicator	POW	5.7V output from power module
		GPS-R	GPS-R: Red terminal from GPS module
		GPS-B	GPS-B: Black terminal from GPS module

❖ Port Definitions: Gemini S flight controller

Port	Port function	Port	Port function
M1	No connection	PTZ1	No connection
M2	No connection	PTZ2	No connection
M3	No connection	PTZ3	No connection

M4	No connection	PAR/PITCH	No connection
M5	No connection	PHO/ROLL	No connection
M6	No connection	EXT1	EXT1 to EXT1 on Gemini M
M7	No connection	S-BUS	No connection
M8	No connection	EXT2	EXT1 to EXT1 on Gemini M
COM	No connection	AI1	No connection
LED	No connection	POW	5.7V output from power module
		GPS-R	GPS-R: Red terminal from GPS module
		GPS-B	GPS-B: Black terminal from GPS module

6.2.2 Gimbal

The Z1400 gimbal is a three-axis brushless motor direct drive gimbal researched and developed by Zero UAV especially for professional photographic applications. The three axes are each driven by a Brushless Motor with high accuracy and a high speed driver module developed by us. When used with our Multi-Rotor Autopilot, the **Zero UAV Gemini** the gimbal has super strong stability, super high accuracy and super sensitive response.

- GH3/4/α7 professional 3-axis motor driving gimbal with high stability
- Can be operated independently and is compatible with other mobile gimbals
- 360°panorama shooting function
- Supports various lens options.
- Simple access to CF card (memory card)
- Perfectly matches Zero UAV Multi-rotor flight control systems
- 3-axis rotation angle without limit
- High precision IMU module
- Rotation speed of all 3-axes is controllable.
- Expandable wireless remote focus following module
- Can be further upgraded and expanded to carry RED and other cameras.

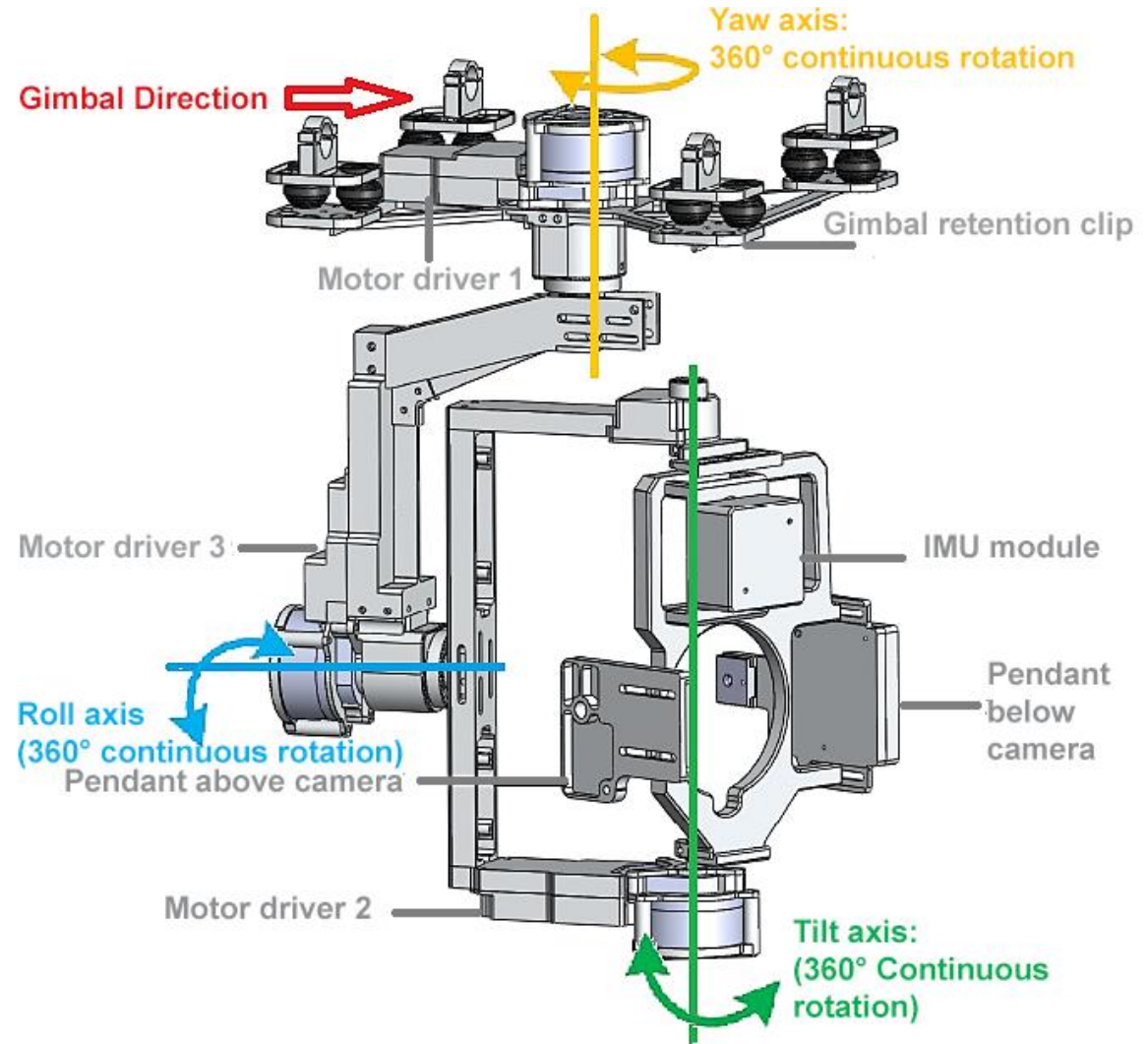

FIGURE 37 Z1400 gimbal

6.2.3 Communication link

Zero UAV have developed ground station APK software for the Android system. This may be installed on a mobile phone or a tablet PC with Wi-fi. The standard Wi-fi module on the HighOne defaults is “point-to-point” mode; allowing the mobile phone ground station to directly communicate with the Wi-fi module on the aircraft, continuously monitoring its status. More information about using the Wi-fi module can be found in the Gemini Autopilot User Manual

6.2.4 Parachute

NOTE :

- The parachute mechanism must take power from the “X4P-PARACHUTE” interface of the main power supply module, do not take power from the flight control or the receiver.
- The weight of whole machine should not exceed the maximum take-off weight of the aircraft outlined in the specifications in order for it to operate effectively.

The parachute is designed to open automatically in an emergency to avoid damaging the camera and to improve the safety of the system. When the real throttle has values, and aircraft is tilted at an angle of greater than 70°, the flight control may sense that the status of aircraft is abnormal, triggering deployment of the parachute. When the parachute opens the motors will stop immediately.

NOTE :

- The parachute will only open automatically, manual deployment is not supported.
- The parachute will not open in circumstances such as interference, rudder vibration, or insufficient power supply and so on.

6.2.5 Landing Gear

- Landing gear wiring

NOTE : The signal of retractable landing gear connect to the empty channel of gimabl receiver, it can also connect to the empty channel in copter receiver.

- Connecting and setting up retractable landing gear can be carried out as follows
 1. The signal wire of left and right retractable landing gear(brown,red yellow wire) plugs in left and right side of copter bracket convert port separately.
 2. switch wire(black, red, white wire) is plugged into an empty channel of gimbal receiver as shown in figure(it can be plugged into an empty channel of copter receiver, too).
 3. Set corresponding channel to two-switch or knob switch in the gimbal remote controller.

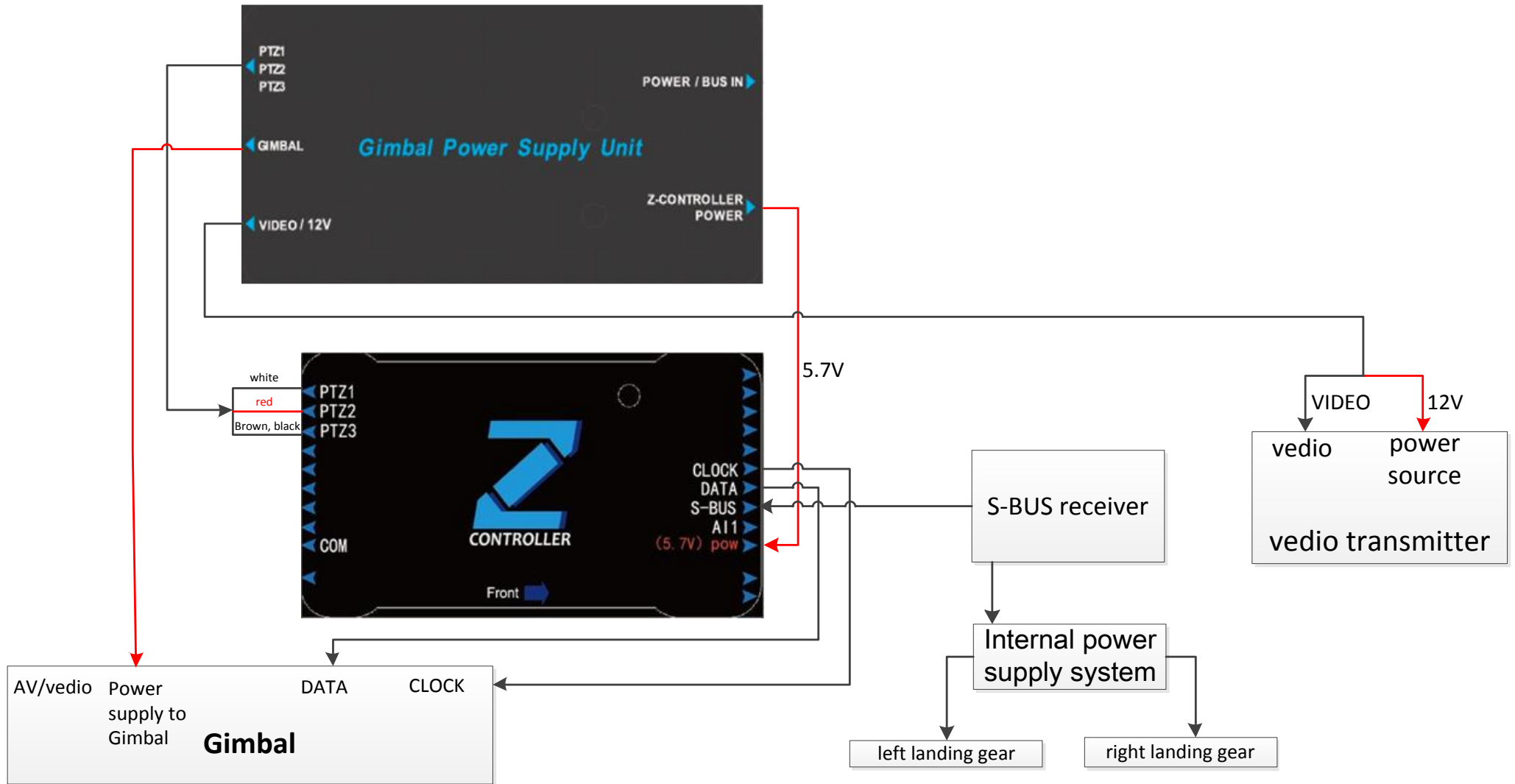

Figure 38 Landing gear wiring

NOTE:: Brown, red, yellow correspond to black, white and red, which is the sequence between the signal wire of left and right retractable landing gear and converter wire ; connectors are fastened by wire clamp in case they come loose.

Appendix 1 Calibrating your remote control. (RC transmitter)

For safety reasons remove power from the aircraft motors, or remove the propellers. Make sure the system is not powered when you do this! Calibrate your RC according to the following steps:

1. Select the correct stick mode for your transmitter.
 - a) After opening the ZERO-GCS Android app, click the mobile phone menu. Click "Set" on the pop-up dialogue.
 - b) Click "Set" to enter the "setting" interface.
 - c) Select your own RC transmitter mode in the "Stick mode" pull-down menu.
 - d) Click "enter".

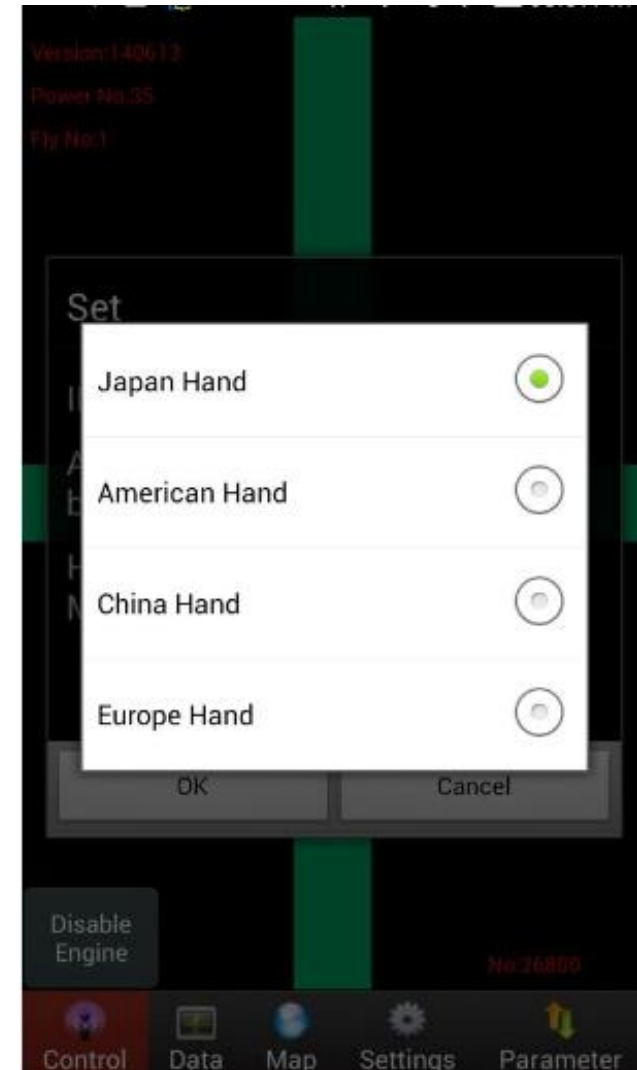

Figure 39 choosing correct stick layout to calibrate stick channel

2. Calibrate RC stick channels (throttle, rudder, aileron and elevator)

a) Calibrate RC stick channels (throttle, rudder, aileron and elevator)

b) Click "OK", within 5 seconds, rotate the right and left stick around their maximum limits. The autopilot will automatically collect the maximum, minimum and the median value for each direction of stick movement.

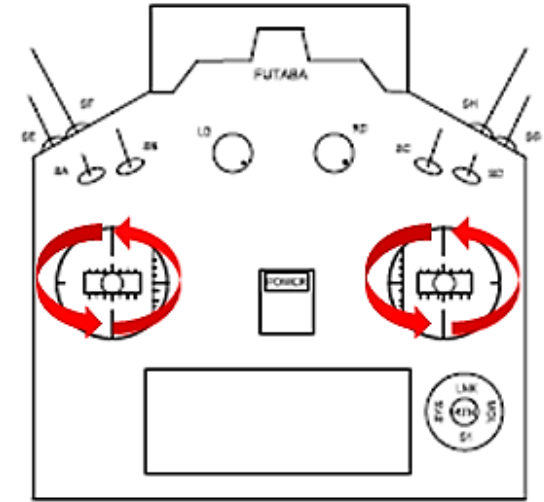

Figure 40 calibrate stick channel

3. Check that the direction of movement of each stick is consistent with the value displayed in the GCS.

a) Check display of stick position.

- Depending upon your transmitter stick mode, the diagram on the data interface the left side shows the elevator and rudder, whilst the right side represents the aileron and throttle. This would be the so-called China hand mode.
- All stick positions appear green in the middle position, the throttle appears yellow when pulled to bottom the rudder, elevator and aileron appear red outside the middle position.

b) If you have completed fine adjustment and a manual position is not showing as dead centre after releasing stick, then you must go to the settings interface and select "Collect middle position of remote control." The middle position will now be recorded correctly.



Figure 41 view stick direction

Appendix 2 Reset gimbal gyro to zero

Gyro may drift, which lead to gimbal turns itself without moving stick, when range of temperature is too big (extremely cold or overheat). Gyro should be reset to zero in that situation. We make an example here with FUTABA, put gimbal in a stable table, throttle is pull to the down, thus there isn't force to the gimbal motor, turn the gimbal to see whether it can stay in one position stably. **Rudder to the most left, elevator to the down, aileron to the most right, throttle to the down (up down shape for Chinese Hand and European Hand)**, stay for about half second, let it go, gyro begin to reset to zero (keep still during the process). Gyro has been reset to zero after 3-5 seconds, righting the camera, push the throttle to top position then gimbal can be used.



Figure 42 reset gyro to zero (example with Japanese Hand)

❖ Resetting the gimbal in single remote control operation

1. Switch CH5 to position one and pull the throttle stick back to minimum (loosening the gimbal motor).

2. Move the gimbal to any position and it should stay in that position without moving.
3. Rapidly switch CH6 between position 1 and position three 3 times, automatically starting to reset the pan axis. The camera should keep absolutely still during this reset operation.
4. After 5 seconds, the reset operation will be completed, hold the camera roughly upright and slightly push the throttle stick (about 5%). You should be at the required level of stability and you will be good to go.

❖ **Resetting the gimbal in dual remote control operation**

1. Reduce the throttle stick of the gimbal remote control to minimum , loosening the gimbal motor.
2. Move the gimbal to any position and it should stay in that position without moving.
3. Stick should be reversed V shape hand or V shape hand, stay for half second and then let it go, the Gyro is reset to zero.
Keep still during the process.
4. Gyro is reset well after 3-5 seconds, righting the camera, throttle should be to the top position then it could be used.

Appendix 3 Supported by Zero UAV technology

If you meet any problems when operating this equipment, please contact Zero UAV for technical support. Relevant technical files: manuals, software and firmware can be downloaded from the support area of the official Zero UAV website.

❖ Website: www.zerouav.com

❖ Telephone: 010-82825376

❖ QQ groups: 168451730 (group 1), 228669705 (group 2), 242018689 (group 3), 53371874 (group 4)

❖ FAQ : http://www.zerouav.com/support_questions.html

Appendix 4 Manual revisions

No.	Ver.	Changes	Changer	Date	Note
1	V1.0	Ver. 1 prepared	Technical Support	2014.12	

Appendix 5 CE

Bulgarian Български	Снастоящето, Manufacturer декларира, че това безжично устройство е в съответствие със съществените изисквания и другите приложими разпоредби на Директива 1999/5/EC.
Czech Česky	Manufacturer tímto prohlašuje, že tento Radio LAN device je ve shodě se základními požadavky a dalšími příslušnými ustanoveními směrnice 1999/5/ES.
Danish Dansk	Undertegnede Manufacturer erklærer herved, at følgende udstyr Radio LAN device overholder de væsentlige krav og øvrige relevante krav i direktiv 1999/5/EF
Dutch Nederlands	Hierbij verklaart Manufacturer dat het toestel Radio LAN device in overeenstemming is met de essentiële eisen en de andere relevante bepalingen van richtlijn 1999/5/EG Bij deze Manufacturer dat deze Radio LAN device voldoet aan de essentiële eisen en aan de overige relevante bepalingen van Richtlijn 1999/5/EC.
English	Hereby, Manufacturer , declares that this Radio LAN device is in compliance with the essential requirements and other relevant provisions of Directive 1999/5/EC.
Estonian Eesti	Käesolevaga kinnitab Manufacturer seadme Radio LAN device vastavust direktiivi 1999/5/EÜ põhinõuetele ja nimetatud direktiivist tulenevatele teistele asjakohastele sätetele.
Finnish Suomi	Valmistaja Manufacturer vakuuttaa täten että Radio LAN device tyyppinen laite on direktiivin 1999/5/EY oleellisten vaatimusten ja sitä koskevien direktiivin muiden ehtojen mukainen.
French Français	Par la présente Manufacturer déclare que l'appareil Radio LAN device est conforme aux exigences essentielles et aux autres dispositions pertinentes de la directive 1999/5/CE
German	Hiermit erklärt Manufacturer , dass sich dieser/diese/dieses Radio LAN device in Übereinstimmung mit den

Deutsch	grundlegenden Anforderungen und den anderen relevanten Vorschriften der Richtlinie 1999/5/EG befindet". (BMW) Hiermit erklärt Manufacturer die Übereinstimmung des Gerätes Radio LAN device mit den grundlegenden Anforderungen und den anderen relevanten Festlegungen der Richtlinie 1999/5/EG. (Wien)
Greek Ελληνική	με την παρούσα Manufacturer δηλώνει ότι radio LAN device συμμορφώνεται προς τις ουσιαστικές απαιτήσεις και τις λοιπές σχετικές διατάξεις της οδηγίας 1999/5/ΕΚ.
Hungarian Magyar	Alulírott, Manufacturer nyilatkozom, hogy a Radio LAN device megfelel a vonatkozó alapvető követelményeknek és az 1999/5/EC irányelv egyéb előírásainak.
Italian Italiano	Con la presente Manufacturer dichiara che questo Radio LAN device è conforme ai requisiti essenziali ed alle altre disposizioni pertinenti stabilite dalla direttiva 1999/5/CE.
Latvian Latviski	Ar šo Manufacturer deklarē, ka Radio LAN device atbilst Direktīvas 1999/5/EK būtiskajām prasībām un citiem ar to saistītajiem noteikumiem.
Lithuanian Lietuvių	Šiuo Manufacturer deklaruoja, kad šis Radio LAN device atitinka esminius reikalavimus ir kitas 1999/5/EB Direktyvos nuostatas.
Maltese Malti	Hawnhekk, Manufacturer , jiddikjara li dan Radio LAN device jikkonforma mal-ħtiġijiet essenzjali u ma provvedimenti oħrajn relevanti li hemm fid-Direttiva 1999/5/EC.
Polish Polski	Niniejszym Manufacturer oświadcza, że Radio LAN device jest zgodny z zasadniczymi wymogami oraz pozostałymi stosownymi postanowieniami Dyrektywy 1999/5/EC.
Portuguese Português	Manufacturer declara que este Radio LAN device está conforme com os requisitos essenciais e outras disposições da Directiva 1999/5/CE.
Romanian	Manufacturer declară că acest dispozitiv fără fir respectă cerințele esențiale precum și alte dispoziții

Romană	relevante ale Directivei 1999/5/EC.
Slovak Slovensky	Manufacturer týmto vyhlasuje, že Radio LAN device spĺňa základné požiadavky a všetky príslušné ustanovenia Smernice 1999/5/ES.
Slovenian Slovensko	Manufacturer izjavlja, da je ta radio LAN device v skladu z bistvenimi zahtevami in ostalimi relevantnimi določili direktive 1999/5/ES.
Spanish Español	Por medio de la presente Manufacturer declara que el Radio LAN device cumple con los requisitos esenciales y cualesquiera otras disposiciones aplicables o exigibles de la Directiva 1999/5/CE
Swedish Svenska	Härmed intygar Manufacturer att denna Radio LAN device står i överensstämmelse med de väsentliga egenskapskrav och övriga relevanta bestämmelser som framgår av direktiv 1999/5/EG.
Turkish Turk	Manufacturer bu kablosuz cihazın temel gereksinimleri ve 1999/5/EC yonergesindeki ilgili koşulları karşıladığını beyan eder.